

HARLEY-DAVIDSON

Model 7 (1911)

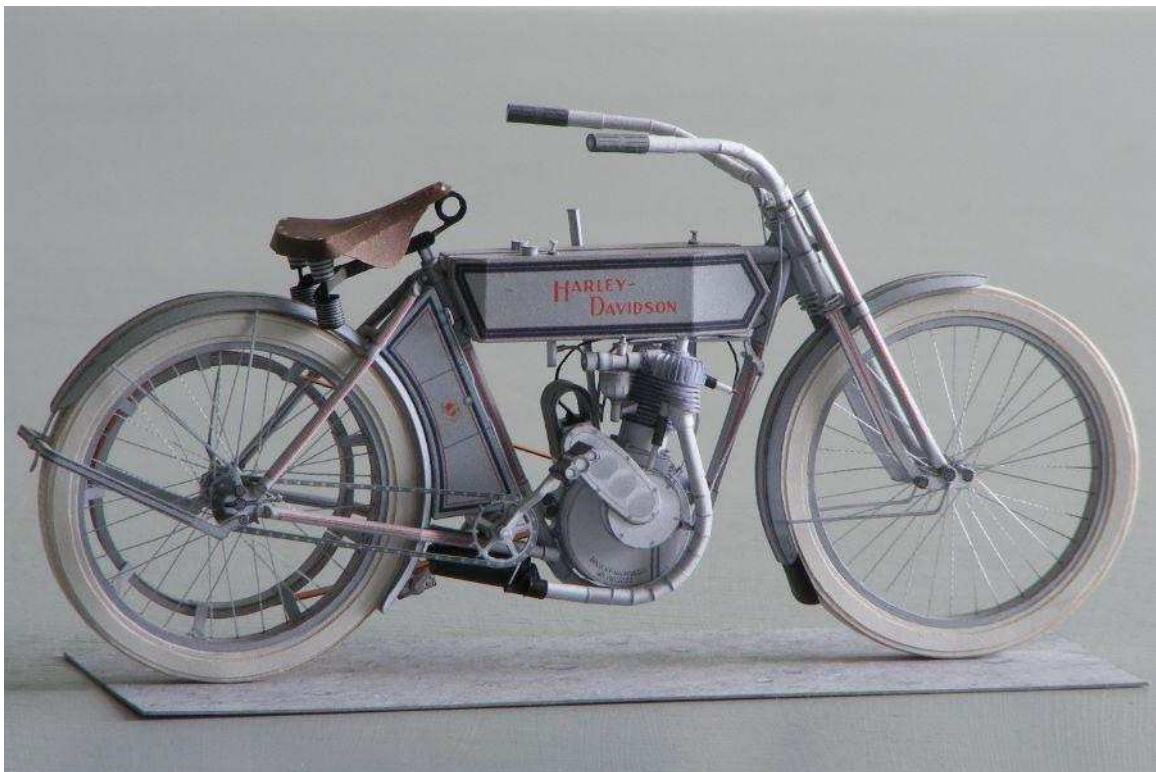

PAPER MODEL

V1.1

Scale 1:7

Alan Grayer 2012
harley@grayer.me.uk

Harley-Davidson belt drive singles.

In 1901 William Harley and Arthur Davidson started work on a motorised bicycle using a small (116cc) engine and a pedal-cycle frame. This was completed by 1903, but turned out to be greatly underpowered, and as a result not a success. The following year they, together with Arthur's brothers Walter and William, had a new design. This had a frame with an S-shaped front tube, forming a circular space for a much larger engine, but otherwise was still very much a bicycle with a motor attached. Production continued until 1908 with minor improvements but no major change in appearance.

In 1909 a new model appeared showing marked changes. The frame was strengthened by adding a second horizontal top tube, and new fuel and oil tanks were fitted surrounding the two tubes and fitted front and rear to the shape of the opening. Previously the tanks were of rather arbitrary shape and size, and strapped on in a rather ad hoc way. This was beginning to look like a purpose-built motorcycle.

Two changes occurred in 1911. The S shaped front tube was replaced by a straight one. As a result, it met the head tube at a steeper angle, which meant that the head tube had to be moved forward slightly to make room, increasing the wheelbase correspondingly. Unfortunately the shape of the tanks was not changed, so they no longer fitted the frame angles neatly. The engine was given a new cylinder head with vertical radial cooling fins - previously the horizontal fins of the cylinder were continued over the head as well.

In 1912 a new saddle mounting was introduced - the "Ful-Floteing" seat. Instead of being clamped rigidly in the top of the rear tube of the frame, the saddle tube was allowed to slide, constrained by springs inside the rear tube. In order to allow this movement, the rear tube had to be cut down by several inches, and the rear third of the tanks and top tube were sloped down to match. At the same time, the front of the tanks was redesigned to fit the new front geometry. This year also saw the first chain drive, fitted to the V-twin version together with a rear-wheel clutch. Over the next three years chain drive was introduced on more models, and by 1915 belt-driven models had been phased out altogether.

The Model

This is based on the 1911 Model 7A, with magneto ignition and 28" (overall) wheels, but also contains parts for making Model 7 with battery ignition. The design is taken from some of the many photographs to be found on the WWW, and is inevitably somewhat speculative in places. A particular problem is that almost all of the photographs are of restored examples, and they differ from each other in detail quite significantly, especially in the painting scheme. It would be best considered as a model of a possible restoration, where a good attempt at authenticity has been made, but where some inaccuracies are to be expected.

The model is to a scale of 1:7 and will measure approximately 300mm x 80mm x 150mm (12" x 3" x 6"). It is designed for printing on thin card 0.2mm thick, typically corresponding to a paper weight of 160gsm. The PDF file is for A4 paper size, but with two exceptions all the parts are within a 7.5" x 10" rectangle, so should print comfortably on US Letter size paper. The exceptions are the two wheel rims on pages E1 and E3, which are marginally longer than 10", but are still unlikely to cause problems.

The model is divided into logical sections in the parts file, identified by the letters A-H. Within each section the parts are numbered sequentially from 1, roughly in the order they appear on the sheets. The instructions are similarly divided into sections, except that there is no section H (conversion to Model 7). Instructions for the conversion process are included in the appropriate sections A-G, highlighted in italics. In each section of instructions parts for that section are identified just by their number; reference to parts from other sections are preceded by their section letter. Where a part number is followed by * the part should be laminated on thicker card, to give a total thickness of 1mm; where they are followed by ** they should be laminated to thicker material - this is always mentioned in the textual instructions.

This kit is not intended for beginners. The instructions identify the parts and give a suitable assembly sequence, but do not describe detailed construction techniques. It is made available free of charge for private non-commercial use. You are welcome to distribute it unchanged to others, and to make modifications for personal use.

A. Frame

Roll the top tube 2 and add the sleeves 1 and 3 where marked. Do the same for the middle tube (4, 5 and 6), down tube (7 and 8) and rear tube (12, 13, 14 and 15). Roll the bottom tube 10, remove the cutouts and form the curved section. Glue the ends of the engine mounting brackets 9 and 11 back-to-back, forming them around the bottom tube, but not yet gluing them. Make rolled connectors to fit half inside each end of the bottom tube, and half inside the down and rear tubes. Glue these all together, then place the engine brackets over the joins. Glue the ends of the middle tube to the markings on the down and rear tubes.

the ends of the top tube to the head and down tubes at the front, and to the rear tube. Glue the strengthening webs 20, 21 and 22 in the angles formed by the head, top and down tubes.

Make up the pedal tube 23, 24 and 25 and the brace 26 and fit where marked to the rear tube. The long projection of the pedal tube is to the left side, and the seam goes at the bottom.

Model 7A:

Make up the seat box 54 and fit to the rear tube and pedal brace.

Model 7:

Omit part 54, instead making the seat box from parts H1-5. The triangular projection made from

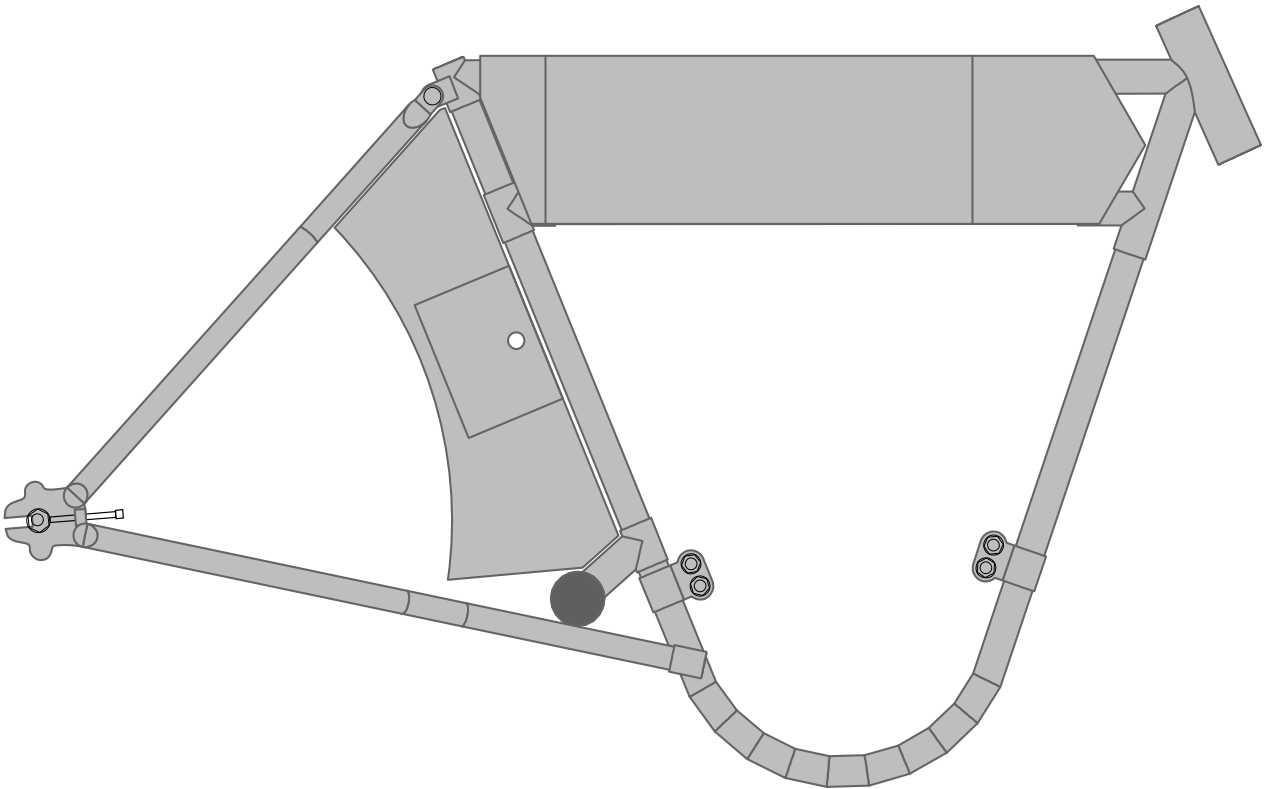

Roll the head tube 18, and add the bearing rings 16 and 17 to the top, and 19 to the bottom, after laminating these to card to a thickness of 1mm. Glue the head tube to the down tube, using the diagram to get the angle correct.

Construct the tank 53. Before cutting out, use the guide lines to score lightly across the sides, front and rear, to allow them to taper in. Cut out the rectangles marked with a red X, then form the shape, tucking the final rectangular panel on each side up inside, to form a groove for the middle tube. Pass the top tube through the holes in the tank, and fit this down over the middle tube. Glue

parts H2 and H3 goes on the right-hand side - that made from parts H4 and H5 goes on the left, with the small holes in H4 towards the front and in the outer half of the projection. Glue H7 and H10 to the backs of H6 and H9 (with card between), then glue these to the ends of rolled-up part H8 with parts H6 and H9 to the outside, and the seam lined up with the centre of their mounting brackets. Mount this induction coil on the front side of the frame's rear tube approximately midway between the pedal stay mounting bracket and the bottom of the fuel tank.

Roll the left chain stay 29, and bend to the shape shown in the diagram. Add the front bush 28 and 27 and the rear capping 30 and 31. The semicircular portions of 30 and 31 are glued back-to-back, and the egg-shaped halves cap the V-shaped end of the chain stay. Repeat for the left rear stay (32-36), right rear stay (42-46) and right chain stay (48-52). Make up the stay bracket (38, 39 and 40) and fit to the rear tube just above the seat box. Roll the crosspiece 41, then mount all the stays to the rear tube.

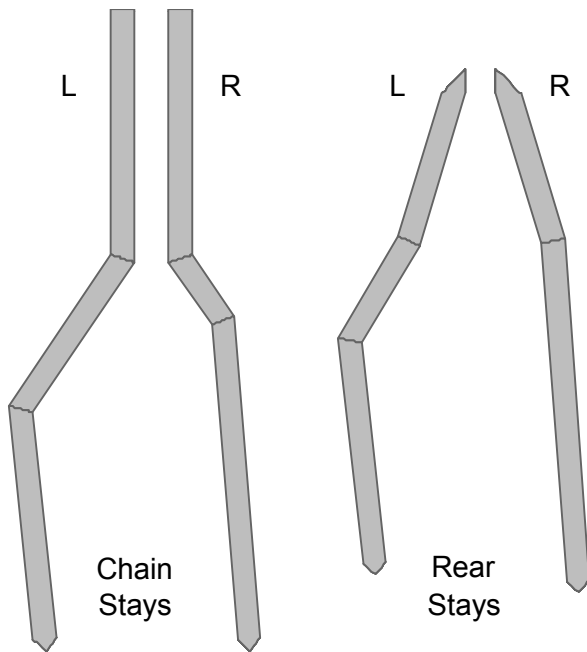

Laminate and cut out the wheel bearers 37 and 47 and the chain 72, and fit to the frame, remembering to thread the right chain stay through the hole in the chain before fitting the right wheel bearer.

The gas and oil fillers (55, 56 and 63, 64) and pumps (57-62 and 65-71) can be made up now, but are best not fitted to the tank until the end of construction.

B. Engine

Start with the cooling fin stack. Glue 26 to the underside of 12 (this will form a plug to locate the lower cylinder skin 76). Glue 25 on top of 12, then 11 on top of 25, lining up the cutouts on 11 and 12. Continue with all the other layers, until the stack is complete with part 1 on top. When fitting parts 1-5, the right-hand edges of the smaller circles should line up vertically - the left-hand edges slope. The stack should match the height as shown in the diagram, though there is no harm in its being a little short. If it is a small amount too tall, it can be squeezed in a vice to get it right.

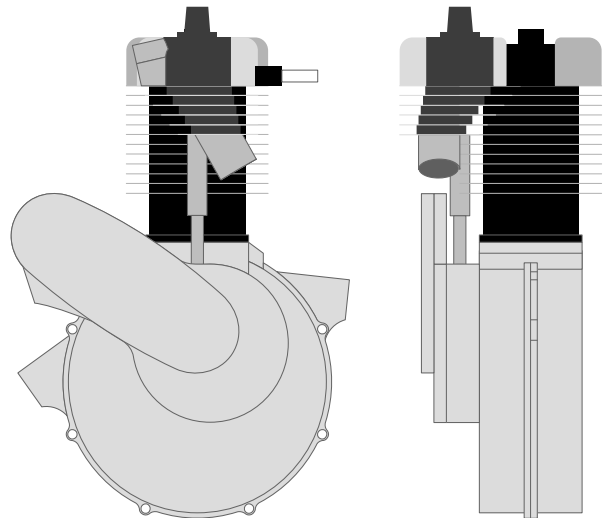

Form the cylinder head core 27 and 28 and glue to the top fin. Make the top 29 and 30, and glue on part 27. Add the valve chamber head core 31 and 32, flange 33 and 34 and inlet valve cover 35 and 36. Add the head fins 37-42, 45-54 and 57-60 around the valve chamber head, as shown in the diagram. The radiused corner of each fin is the top outside corner.

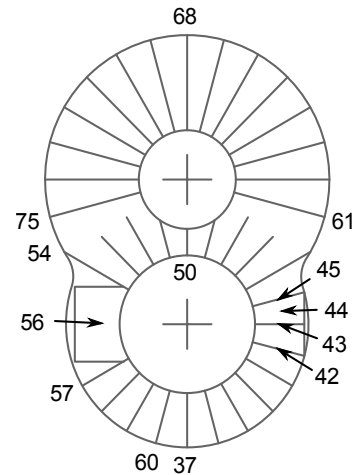

Not to scale

Fit the spark plug boss 44 between fins 42 and 45, and glue the short fin 43 on top. Make up the carburettor mounting 55 and 56, and fit between fins 54 and 57. Fit the cylinder head fins 61-75 (these are all the same). Both top corners are radiused - the larger radius goes to the outside.

Roll the cylinder base 76, and fit over the plug 26. Roll the exhaust stub 77, valve spring 78 and valve stem 79. Fit the valve spring into the cutouts in fins 7-12, with its seam towards the cylinder axis, and top touching the underside of fin 6. Glue the exhaust stub centrally underneath the small circle of fin 6. Slide the valve stem 79 inside the spring 78, but do not glue.

Optionally glue the cylinder bolt heads 81-84 over the markings on the flange 80, then glue the completed cylinder in the centre.

Laminate 85 and 86 to card, glue 87 to the back of 86 and cut out. Glue back-to-back. Roll 89 and 91, and use 88 and 90 as formers to make them circular. The seam of 89 should line up with the small mark at the top of 88, and similarly with 91 and 90. Glue 88 and 89 to 85, again lining up the seam with the top marking, and glue 90 and 91 to 86.

Model 7A:

Make up the cam cover 94 with 95 as a former, and glue to 88, lining up the seam with the bottom marking on 88. Glue the magneto drive cover 96 over 97, and glue 98 to the back. Then put this on the cam cover 94, lining up the mark at the bottom of 98 with the seam.

Model 7:

Make up the cam cover with parts H12 and H13, lining up the seam of H13 with the small mark at the bottom of H12. Add H11 to the front of H12. Glue the assembly to 88, lining up the seam with the bottom marking on 88.

Fold up and assemble the cylinder mount 92 and glue to the top of the crankcase assembly. Place the front panel 93 over 92 and 88, resting on the cam cover 94 (or H13). Glue the cylinder on top of the mount 92, and glue the bottom of the exhaust valve stem 79 to the top of the cam cover.

Start the carburettor by rolling the main body 99, then adding sleeves 100 and then 101 at the rear end and 102 at the front. Glue the spacers 103 to 106 over the seam: 106 first between 100 and 102, then 105 over the top, butted up against sleeve 101, and then 103 and 104, with the front ends lined up with the front end of 105. Make up the float chamber 109, forming the petals into a hemisphere underneath. Fit the top 108 and the support 110 and 111. Make up the air intake 114, blackening the reverse side first. Glue 105 and 106 back-to-back, and fit to the forward end of 114, with 116 facing outward. Make the centre post 112 and 113, and glue to the middle of 115. Fit the intake to the rear end of the carburettor body 99. Roll the throttle lever support 120, add the lever 119 and the top rod 117 and 118. Fix these to the top of part 99. Glue the carburettor to its mounting on the engine, and make up the bracket 117 and position it between the float chamber support 110 and the cylinder cooling fins.

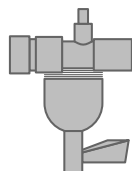

Roll the spark plug pieces 121 and 122, then slide 121 inside 122 and glue to the boss on the cylinder head.

Fold the magneto body 123 into a box, then wrap the front/rear panel 126 around it. Add the ignition cable connector 124 and 125 to the top. Roll up the contact box 127 around the former 128, and glue to the magneto face opposite to the ignition cable connector. Fit the cover 129 over it, with the rolled-up fixing post between the projection and the top right both head on the magneto body. Roll up the drive cover and fit on the opposite side of the magneto. Laminate the mounting bracket 132 to card, and glue the underside 133 to the back. Fit to the magneto body. Form the D-shaped magnet by taping the inner layer 136 coloured-side in to a suitable former. Then laminate the middle and outer layers 135 and 134, trim and fit to the sides of the magneto. Glue the completed magneto to the rear of the drive 98.

Mount the engine in the frame, centrally located in the curve of the bottom tube and attaching the lugs on the flange 86 to the mounting brackets A9 and A10.

Construct the muffler 138-140. The seam in 139 will go at the top, and should be lined up with the mark on the front end 140. Add the inlet trunk 141 and outlet 137 where marked. Make up the inlet 142 and 143, and fit on to the end of 141. Blacken the reverse side of 144, and glue it to the capped end of the inlet.

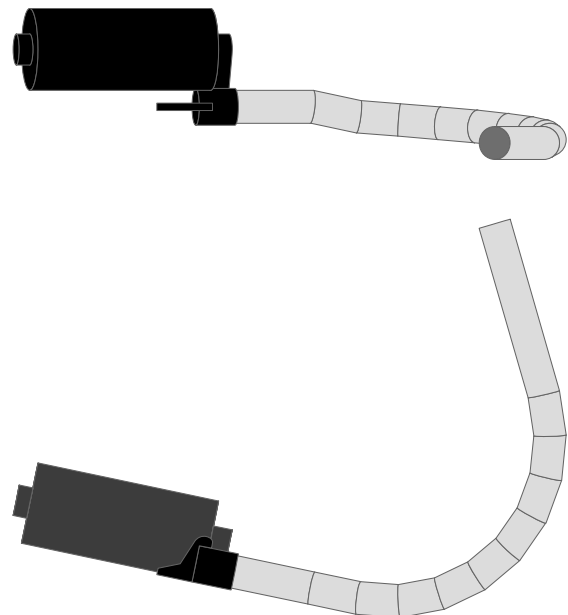

Make up the exhaust pipe 145, shaping it according to the diagram, and fit it between the engine and muffler.

Defer adding the various pipes and cables 146-154 until more of the model is completed.

C. Front Forks

Roll the left main fork top section 2, add the bush 6 to the top, and the spring support 7 to the middle. The spring support should angle 45 degrees forward/inward when the seam of the fork tube faces inwards. The final section with the semicircular cutout runs straight forward. Roll the handlebar support 1, and glue inside the top of part 2, lining up the seams. Roll the spring fork 8, and add the top bush 3 and 4, and the middle bush 5. Repeat for the right-hand side (19-26).

Laminate the yoke layers 27 to 29 to their backing, and cut out the holes and slots and then the parts themselves. Glue the spacers 30 and 31 to card. Assemble the yokes and spacers alternately. Note that the yokes are slightly asymmetric - the centre hole is not quite in line with the centre of the slots. When assembled, the slots should be slightly forward of the hole.

Laminate parts 32 to 37 to card, and glue the reverse colouring on. Cut out the lower main forks 34 and 35, and fit through the slots in the yokes. The top of the yoke is lined up with the boundary between the grey and white section - the top of the red lining should just be visible beneath the yoke. Slightly flatten the bottom of part 2, and fit it over the top of part 34, resting on the top of the yoke. The seam should face inwards. Do the same with 26 and 35.

Roll the top bearing 12 and add the cap 11. Laminate 9 and 13 to card, and add 10 and 14 to the back. Glue these on opposite sides of 12, then fit the assembly between the bushes 6 and 23, forming a ladder arrangement to keep the forks parallel.

Cut out 33, and glue inside the flattened ends of 8. In this case the seam on 8 should face the rear. Part 33 needs to be fitted snugly against the forward edge of the flattened tube, leaving a gap at the rear. Then cut away the tube at the rear to give a smooth curve (see diagram).

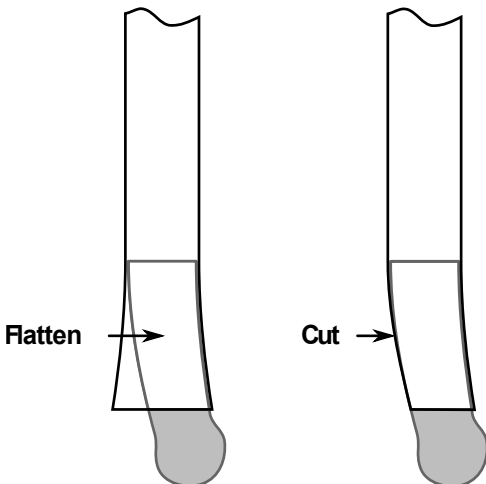

Repeat for 37 and 19. Roll up the cross-piece 15. Glue 16 to card, cut out, and glue to the rear of 17. Fold up the lower section of 17 to form the fender mount. Fit 15 and the 16/17 assembly between the spring forks 8 and 19. The seam on 15 should be down, and the black central mark to the front; the fender mount on 17 goes to the front.

Fit the wheel mounts 32 and 36 to the outside of the spring forks 33 and 37, then add the main forks, ensuring that the spring crosspiece 15 rests in the brackets 7 and 24.

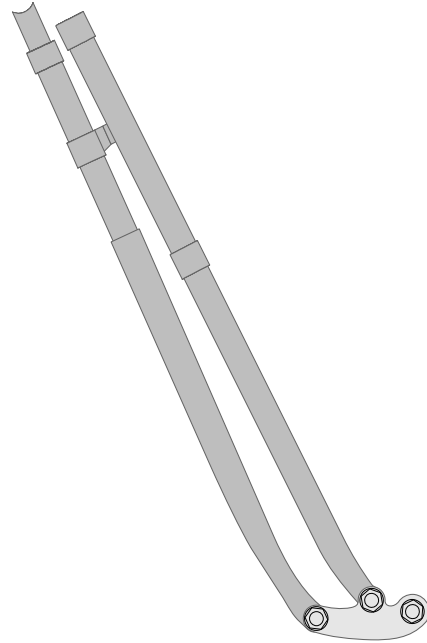

Roll the steering pin 18, then push it upwards through the yoke, the head tube bearings of the frame, and into the top bearing 12. Glue at the bottom.

D. Fenders

Cut out the rear fender sides, leaving the domed cutouts in place at the moment (though you may find it best to cut the curved top of the cutouts, leaving the straight sides connected). Join these sides to the centre section 2 - the cutouts in the sides go towards the forward (square-cut) end of the centre section. Glue the template 11 to something thick (e.g. foamcore), then glue the fender backing 1 inside the centre section of the fender, and wrap the whole thing around the template to dry. This sets in the correct curvature. Finally trim the ends of the inside piece 1 to match part 2, and remove the cutouts from the sides.

Repeat the process with the front fender parts 6-9. Here the screwhead marking on the curved sides goes with the square-cut rear end of the

centre section. Add the mud flap 10 to the rear end.

Glue the finished rear fender to the curved back of the seat box, with the cutouts accommodating the chain stays. Fix the front fender to the mount on the front forks, with the spring fork tubes passing through the cutouts.

The fender stays 12-15 can be laminated, but are best left to be fitted after the wheels.

Glue the stand pieces 16 and 17 to card, and the template 18 to thicker stuff. Fold the inside, 17, around the template, coloured side in, using the marker lines to locate the corners. Glue the outside piece 16 around, forming the correct profile. Shape the stand clip 5 as shown in the diagram.

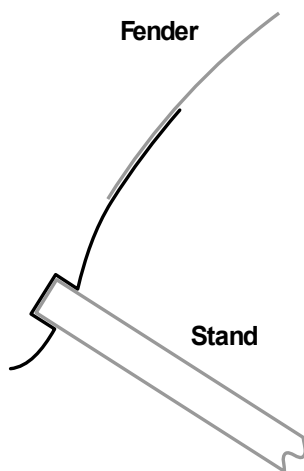

Not to scale

If the model is to be shown on its stand, glue the clip to the back end of the rear fender. If the stand is to be shown clipped up in riding position, glue the clip to the centre of the stand base. Either way do not attach the stand to the model until the wheels are done.

E. Wheels

Form the front wheel rim 1, and use the formers 2 and 3 to keep its edges circular. Roll the axle 4 and fit flanges 6 and 7 over it, printed faces inwards, just inside the marked lines. Fit spokes in your preferred manner, using the template 9 to obtain the correct positions. Glue flanges 5 and 8 over the inner ends of the spokes.

Glue one part 22 on each side to the formers 2 and 3, then add 23 and 21 to suggest a little curve to the sides of the tyre. Fit two pieces 24 around the outside, and then two pieces 25.

Repeat for the rear wheel, using parts 10-19, template 20, and the remaining parts 21-25. Note that the longer end of the hub 13 will be on the left

of the finished model, and parts 14 and 15 are end caps for 13, which will be partially visible.

F. Drive Train

Laminate and cut out the pulley sides 1 and 2. Glue one of the centre circles on thick card, and use as a former for the rim pieces 3 and 4. Then edge-glue the sides to the rim. Double the centre part of each pulley bracket, then glue the longer end of each (with three rivets) to the marks inside the pulley. Glue the other ends to the rear wheel rim.

Make the engine drive pulley. Parts 18 and 19 form the back (engine side) flange, 20 the running surface, and 21, 22 and 23 the front flange.

Roll part 26 with the printing inside, and glue 27 on the outside to form the idler drum. Sandwich card between 24 and 25, and push into one end of the drum. Make up the centre stub 28 and 29, and glue inside. Glue 30 and 31 back to back with card in between, then fit the idler centrally at the narrow end.

Cut out the small slots in the clutch lever 39, then roll it. Glue the bottom end flat, and cut along the lines to give a round end, and add the top 32. Laminate 36, 37 and 38 to card, then assemble in the order 36, 37, 39 and 38, keeping the main part of 36 in line with lever 39. Thread the sector 33 through the slots in 39, then glue the mounting blocks 34 and 35 behind the ends.

Stick the drive belt template 41 to foamcore or something similar, and form the drive belt around it in two layers, parts 14 and 15 on the inside and 16 and 17 outside. Do not join up the final overlap yet. If the model is to be shown in running condition, form the belt tightly to the template, otherwise form it as a loose band.

Roll up the axle 40, and glue into the engine crankcase.

Pass the drive belt through between the left-hand stays, and join up the ends. Put the wheel pulley into the large end of the belt, then fit the wheel to the stays. Place the idler arm over the drive axle but do not glue yet. Glue the engine drive pulley to the axle, with the narrow end of the drive belt around it. For a model in running condition, glue the idler arm to the engine with the idler wheel pressed up against the concavity in the drive belt, and glue the bottom end of the clutch lever to the engine with the lever leaning back. For display as if parked, fix the idler arm near vertical, and the clutch lever fully forward. Finally fix the sector strip mounts to the side of the tank.

Now is the time to add parts deferred from previous sections.

Fix the oil filler (A55, A56) and oil pump plunger (A57-A61) to the markings on the left-hand side of the tank top, and the oil pump body (A62) underneath. Do the same with the gas filler (A63, A64), gas pump plunger (A65-A69) and gas pump body (A70, A71) on the right-hand side. Run the oil tube B152 from the bottom of the oil pump to the right-hand edge of the crankcase, just forward of the cylinder mounting flange. Fix the gas pipe B148 between the side of the gas pump A70 and the carburettor float chamber B109.

Model 7A:

Glue the lever at the bottom of the spark advance cable B149 to the magneto B127, and run the cable over the engine and up to the left-hand handlebar support. Glue the "copper" end of the ignition cable B154 to the end of the spark plug B121, and the other end (trimmed if necessary) to the magneto connection B124.

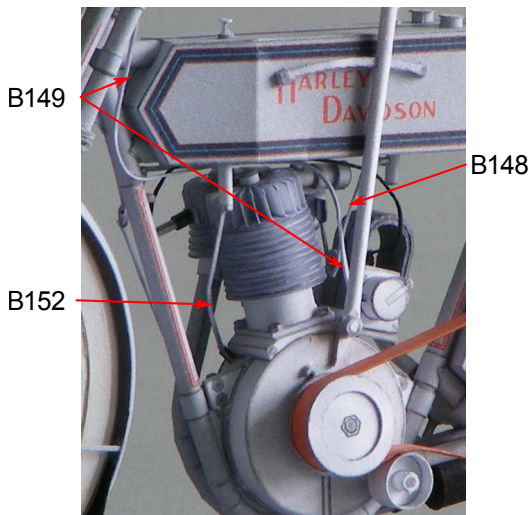

Glue the throttle crank and mounting (B147 and B146) to the down tube just below the tank, with the mounting crosswise on the rear side of the down tube, and the crank to the right. The crank end with two connection marks should be forward and down, the end with just one marking goes rearward of the down tube and up. Link the upper end of the crank to the throttle lever B119 using wire B151. Glue the lever end of B153 to the forward side of the cam cover B94, and trim off the long cable to length to reach the lowest marking on the throttle crank. Use the remainder of this cable to link the second mark at the lower end of the crank to the inside of the right-hand handlebar support C25.

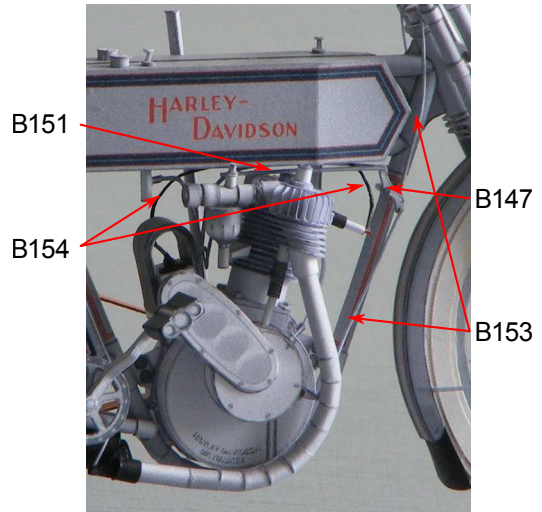

Model 7:

Run the ignition cable B154 from the spark plug B121 over the engine to the top of the induction coil, part H6. Glue the bifurcated end of the battery lead H15 into the holes in part H4, and the other end to the top of the induction coil, part H6.

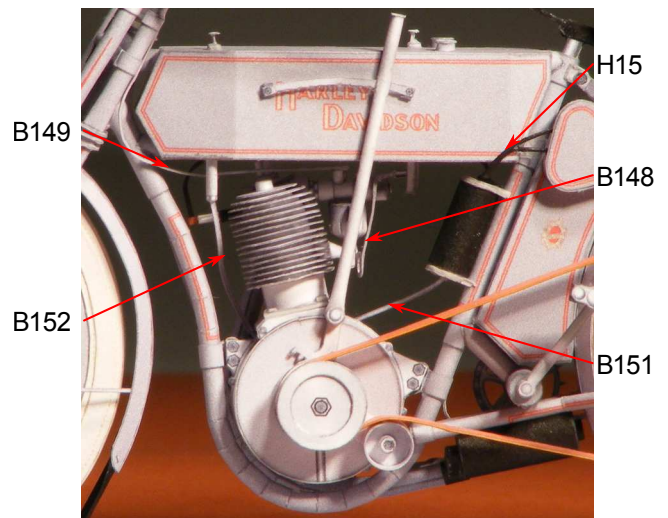

Discard the throttle crank and mounting B147 and B146. Cut off the lever end of B149, and use the remainder to link the throttle lever B119 with the inside of the left-hand handlebar support C1. Glue the lever end of B153 to the forward side of the cam cover B94, and run the cable up to the right-hand handlebar support C25. Roll part H14 and glue over the lever end of B153, then fit the ignition advance linkage H16 between the outer end of H14 and the rounded lower corner of H11. Run B151 from the rearward cutout at the top of the contact breaker H11 to the bottom of the induction coil H9.

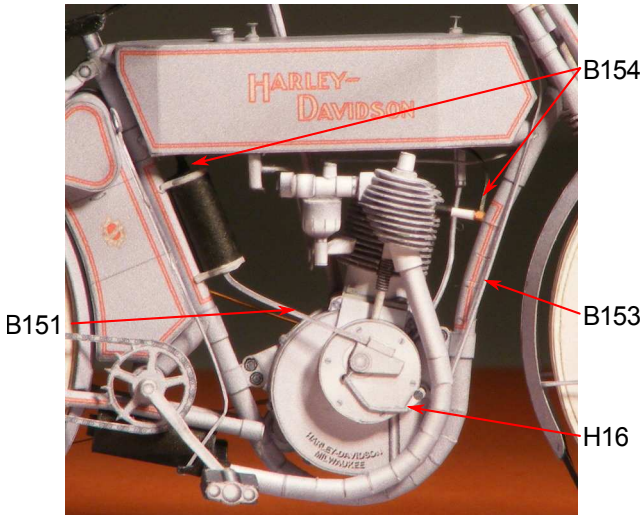

Glue the exhaust control wire B150 to the front right-hand edge of the seat box A54, and then out to the lever B144, trimming as needed.

Fix the front fender stays D12 and D13 to the wheel supports C36 and C32 and to the fender sides C6 and C7. The stays are deliberately overlong, so that they can be bent and trimmed to fit. Fit the rear fender stays D14 and D15 to the rear wheel supports A47 and A37 and the fender sides D4 and D3. The left-hand rear stays have to be bent inwards part-way up, to clear the drive pulley on the rear wheel.

Attach the stand D16/17 to the rear wheel supports A47 and A37 in the desired position, either stowed by the end of the rear fender, or in use facing downwards (and slightly forward) with the top ends against the chain stays A50 and A29.

G. Saddle, Handlebars and Pedals

Assemble the saddle parts 1-4. The small marks next to part 3 indicate where to place the ends of parts 2 and 4.

Make up the left-hand saddle springs (5-7 and 9-11) and join them with the rod 8. Alternatively, use a pin for the central rod, in which case you can paint the reverse of 10 and 11 black, and omit the top cover 9. Make up the right spring (12-18) similarly. Glue the tops of the upper springs to the crosspiece 21.

After laminating to card, glue the saddle supports 19 and 20 back-to-back. Glue 22 and 25 back-to-back and stick over 19, and do the same with 23 and 26 on the other side. Glue 24 on the reverse

side of the tails of 25 and 26 - these tails should diverge at around 45 degrees from the centreline. Glue the crosspiece 21 with the springs to the cutout in 19 and 20, and fix the ends of the diverging tails to the edge of the bottom springs. Glue the stub at the bottom of 19 and 20 into the top of the rear tube A14.

Roll up the handlebars 27, and add the support bushes 31 and 32 where marked. Thicken up the ends with parts 30 and 33, and add the grips 29 and 34 over the ends of these. Remove the lenticular cutouts in part 27, and form up to the shape shown in the diagrams. Finally add the end caps 28 and 35 and glue the whole thing to the top of the front forks.

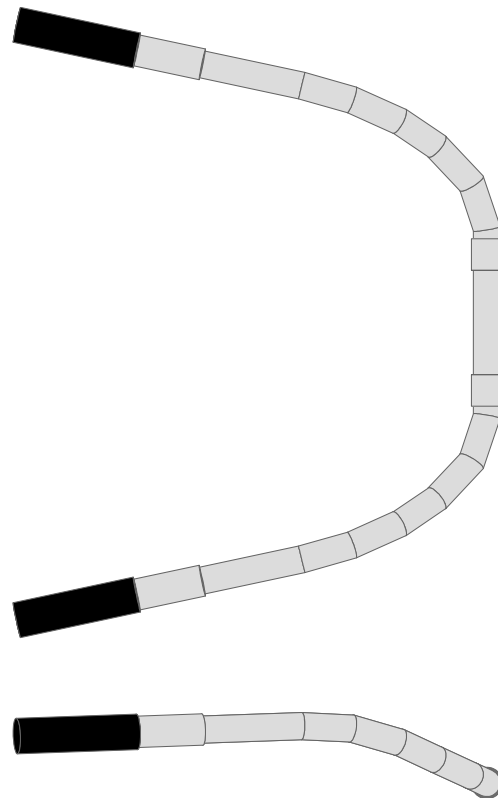

After laminating the pedal arms 36 and 38 to card, glue the wider ends back to back. Bend out at approximately 45 degrees at the first mark, and glue the centre section. Bend back at the second mark, and glue the remainder. Make up the pedal 40, and glue on the ends 42 and 43. Fix to the end of the pedal arm. Repeat for the other pedal (37-45), and glue both pedals to the pedal tube on the frame.

THE MODEL IS COMPLETE.

I hope that you have enjoyed it and are pleased with the result.

Alan Grayer
harley@grayer.me.uk

