

# S-TYPE LONDON BUS



## PAPER MODEL V1.0

Scale 1:32

Alan Grayer 2021  
styp@grayer.me.uk

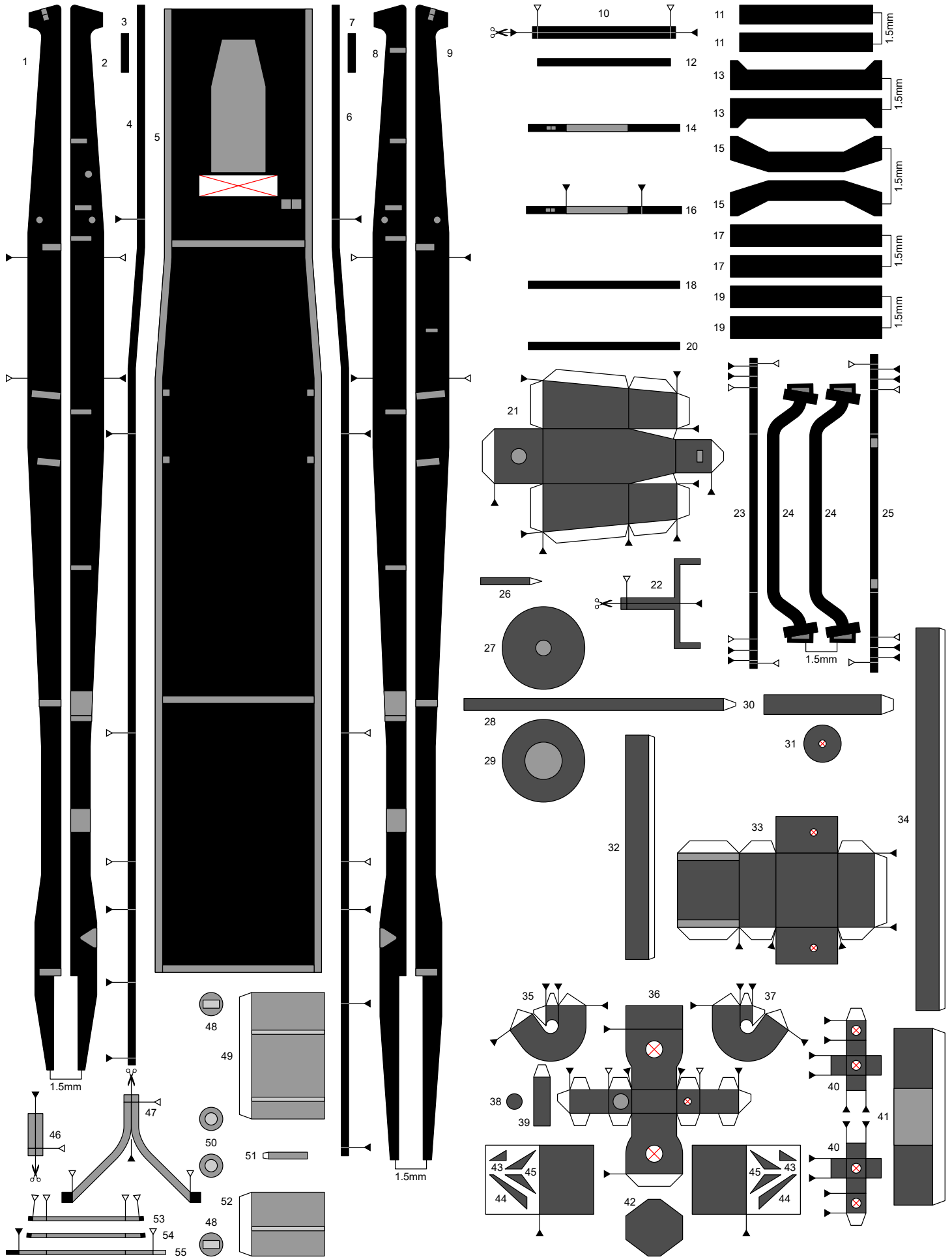

**S-TYPE LONDON BUS 1:32**  
**A: CHASSIS**

**- A1 -**

Alan Grayer 2021  
 stype@grayer.me.uk

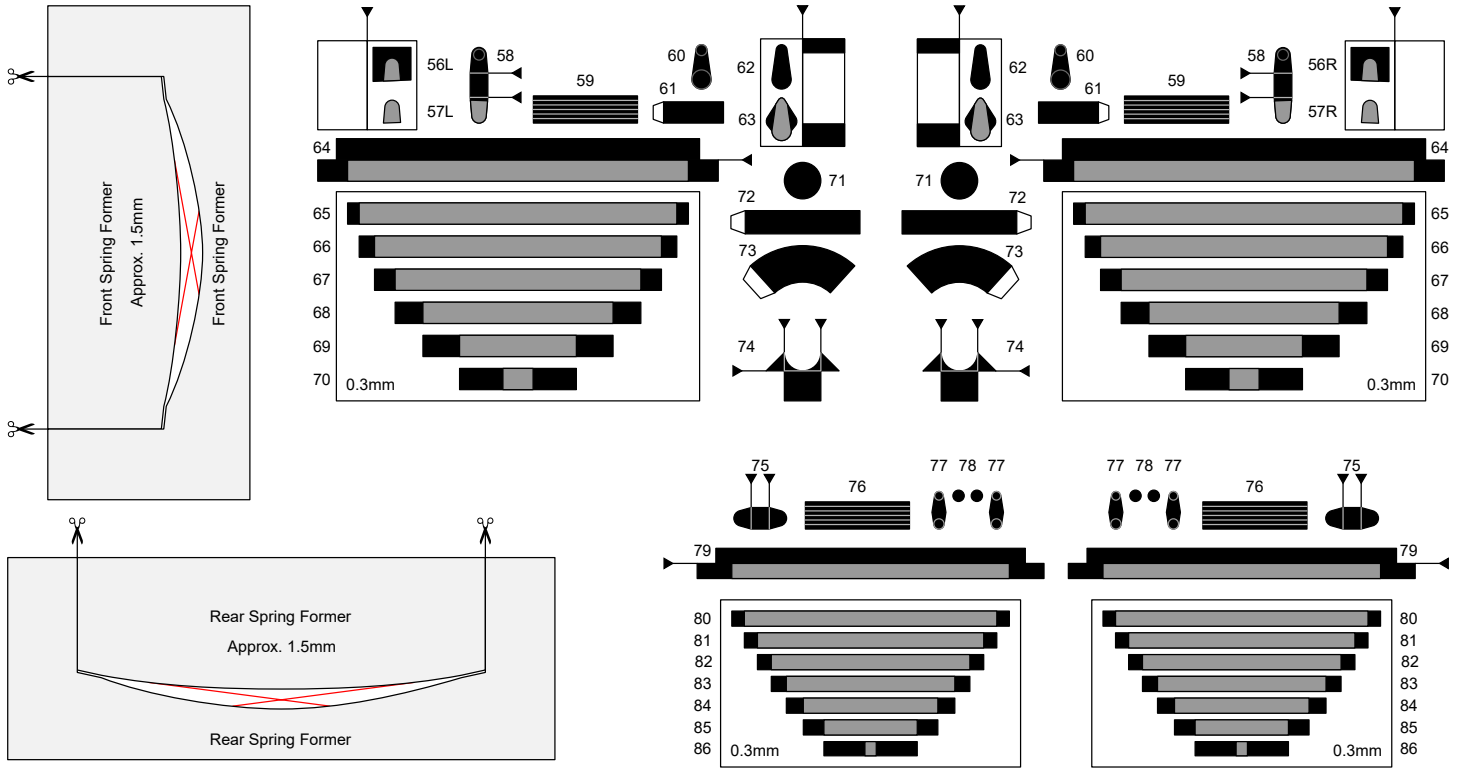

Parts required only if making the simple lower saloon section C

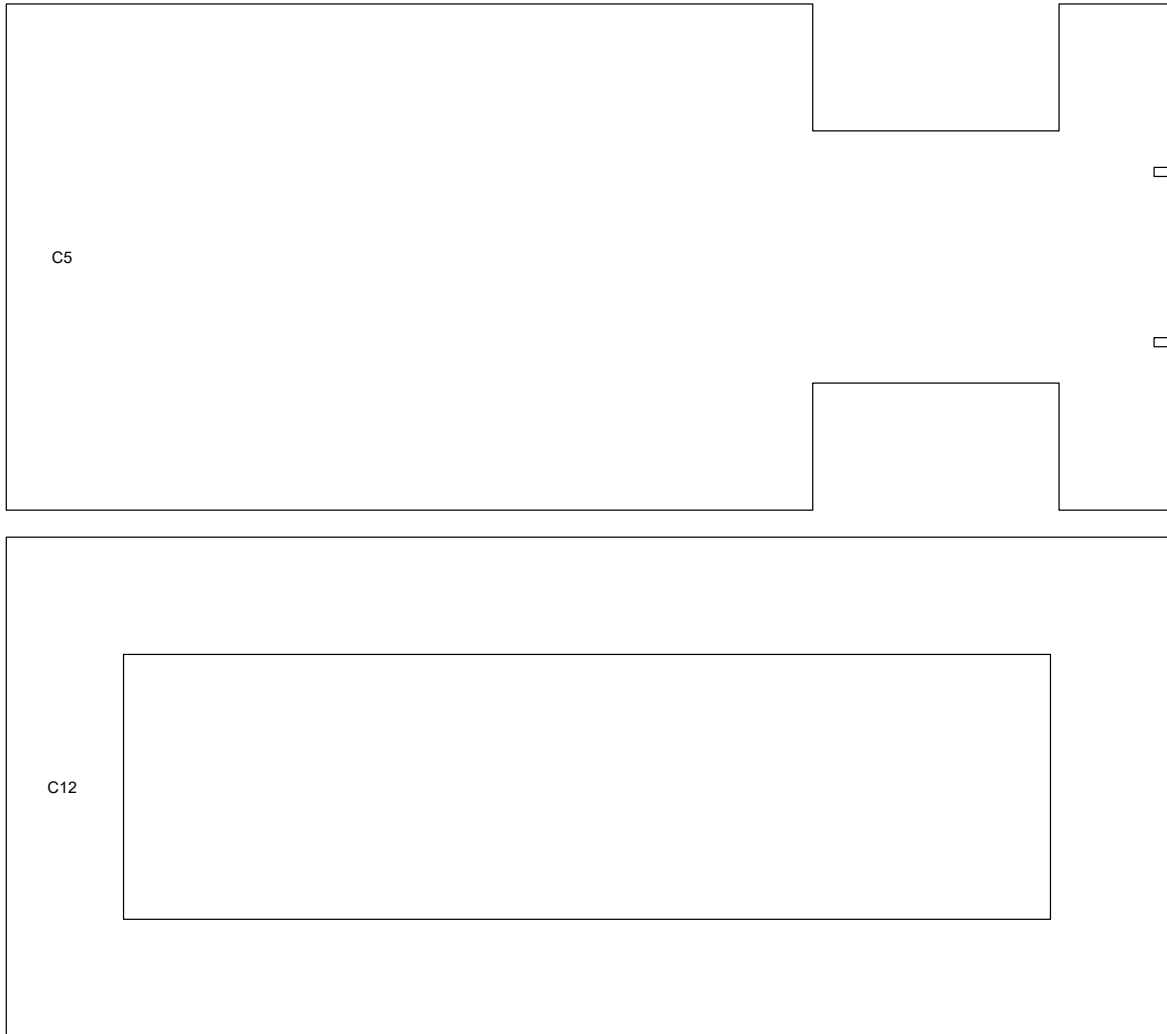

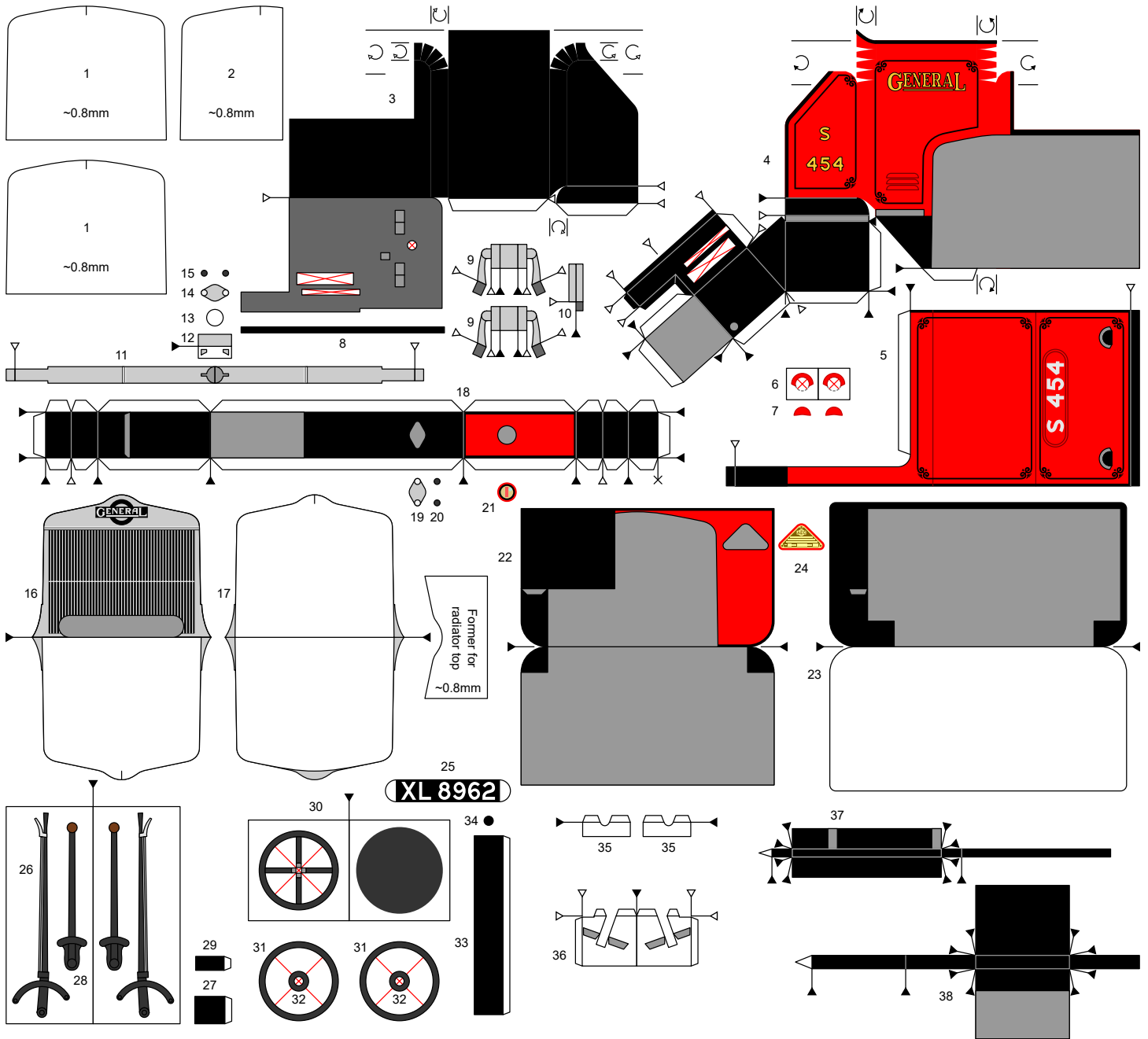

Simplified driver's enclosure

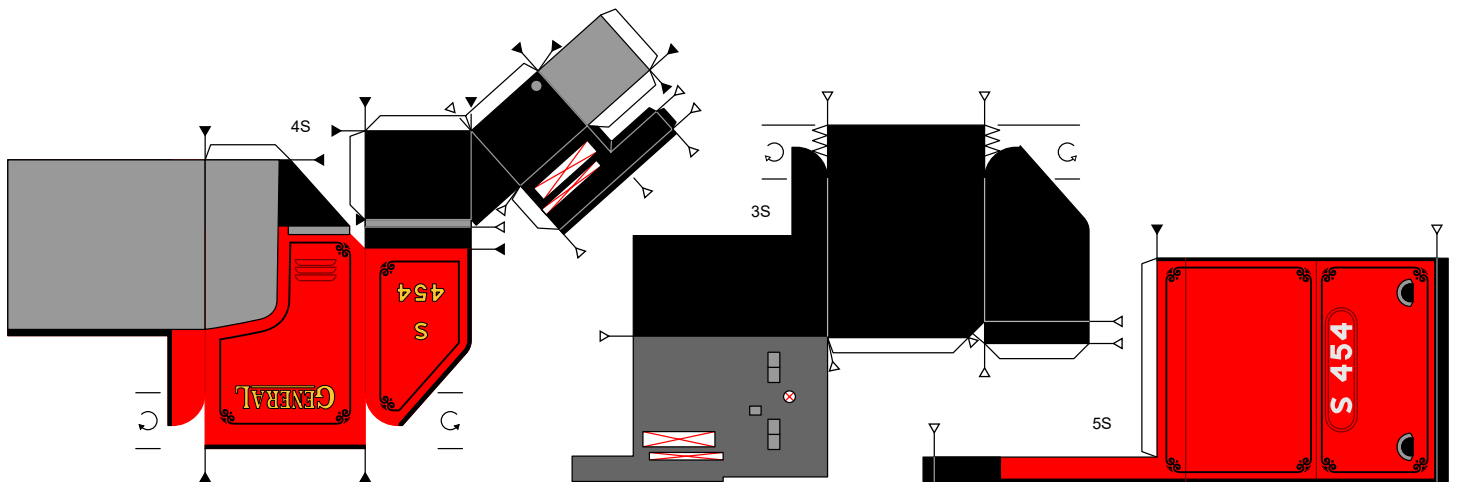

**S-TYPE LONDON BUS 1:32**  
**B: FRONT END**

**- B1 -**

Alan Grayer 2021  
 stype@grayer.me.uk

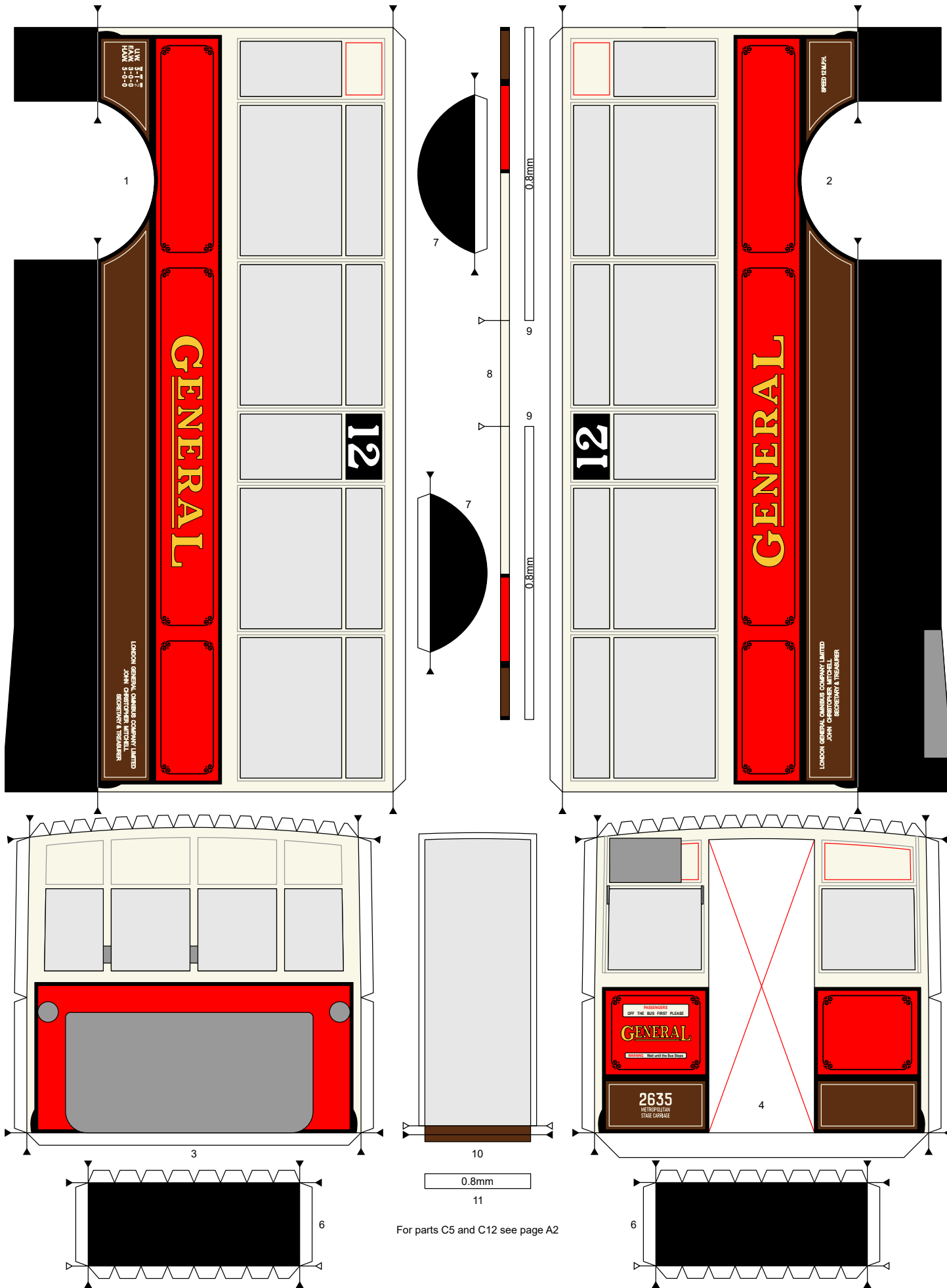

**S-TYPE LONDON BUS 1:32**  
**C: SIMPLE LOWER DECK - C1 -**

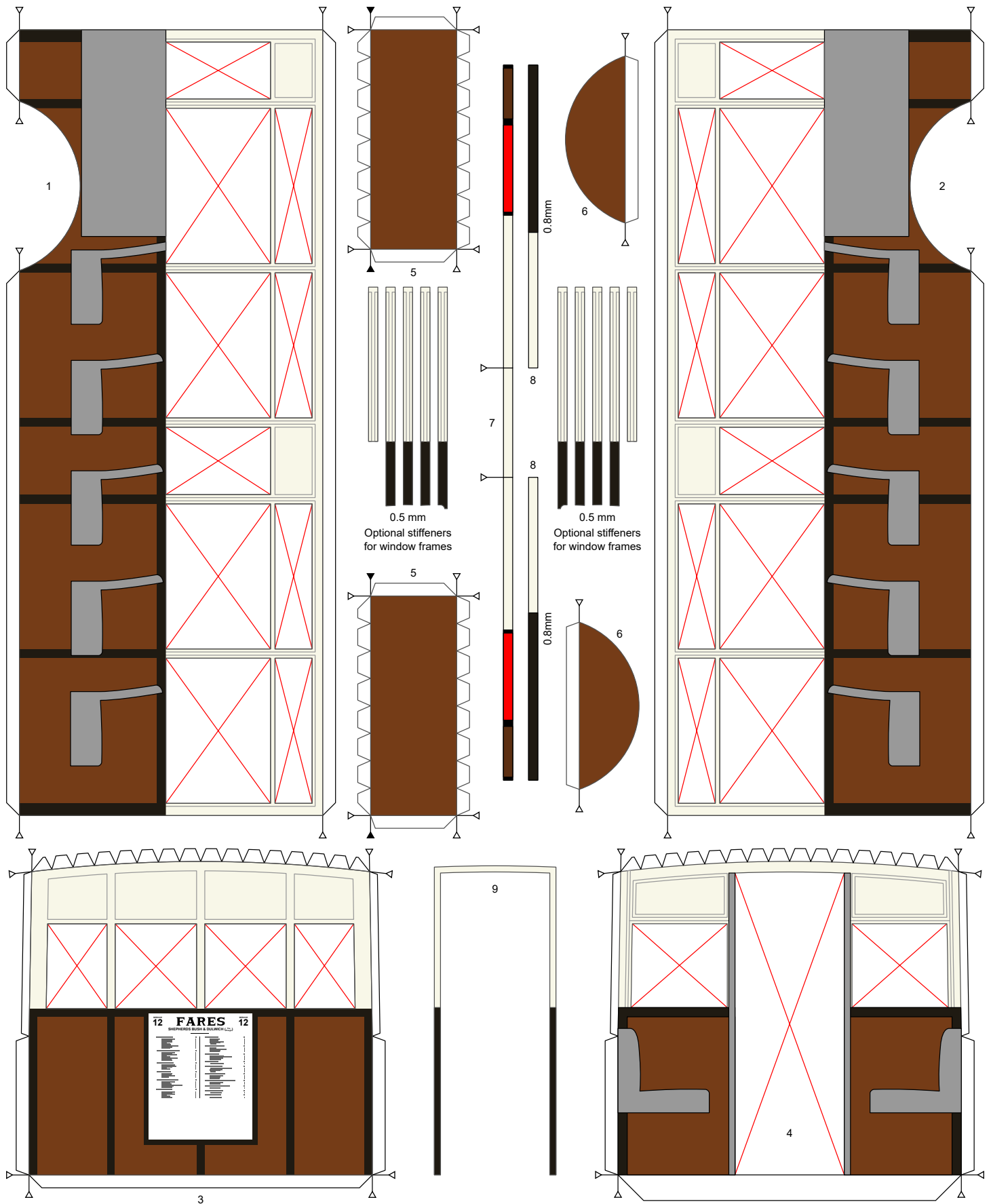

**S-TYPE LONDON BUS 1:32**  
**D: FULL LOWER SALOON - D1 -**

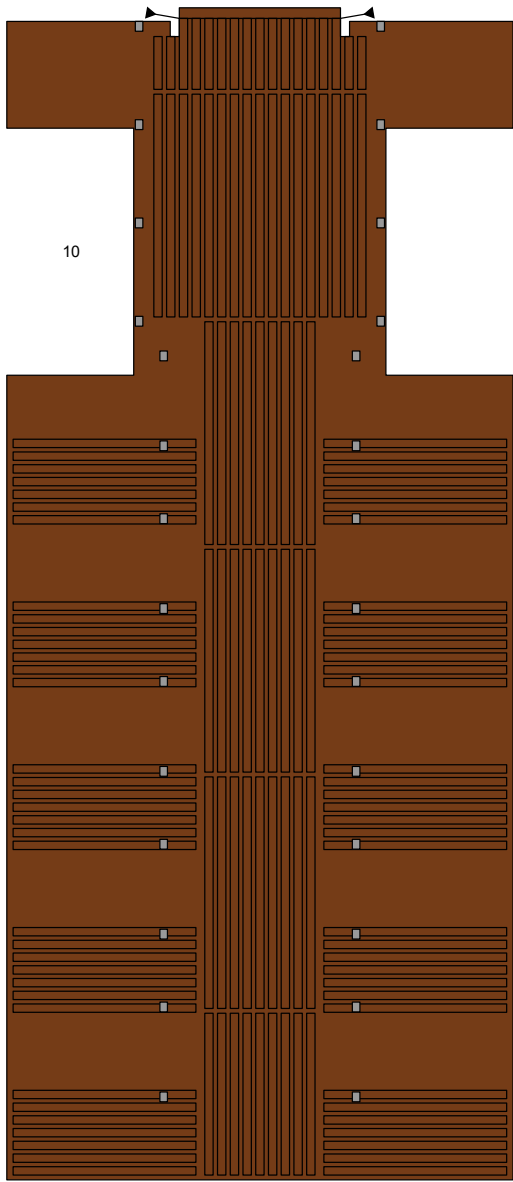

12L

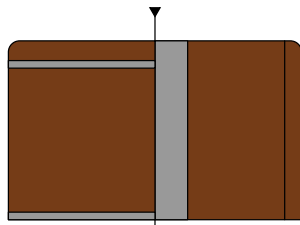

13L

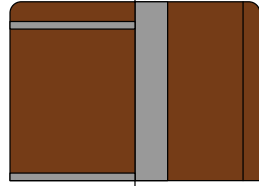

13L

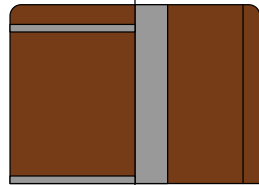

13L

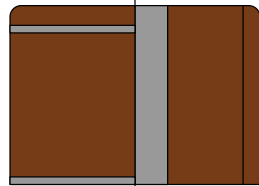

13L

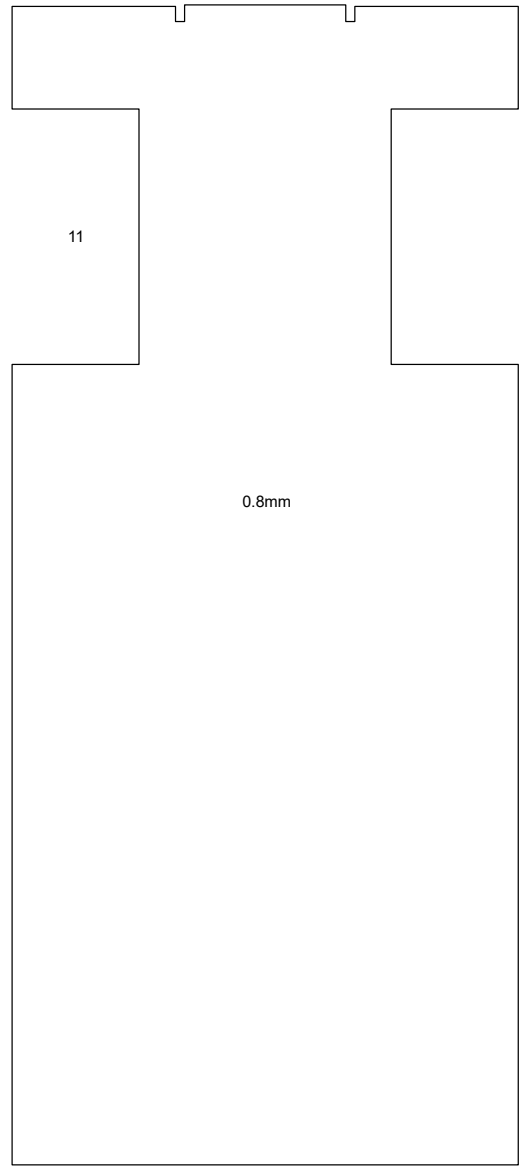
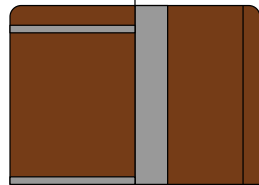

12R

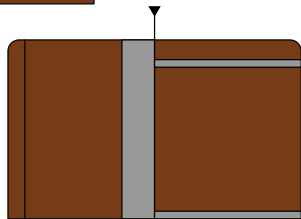

13R

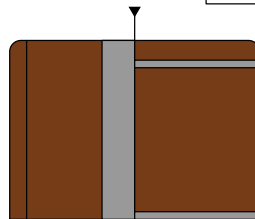

14

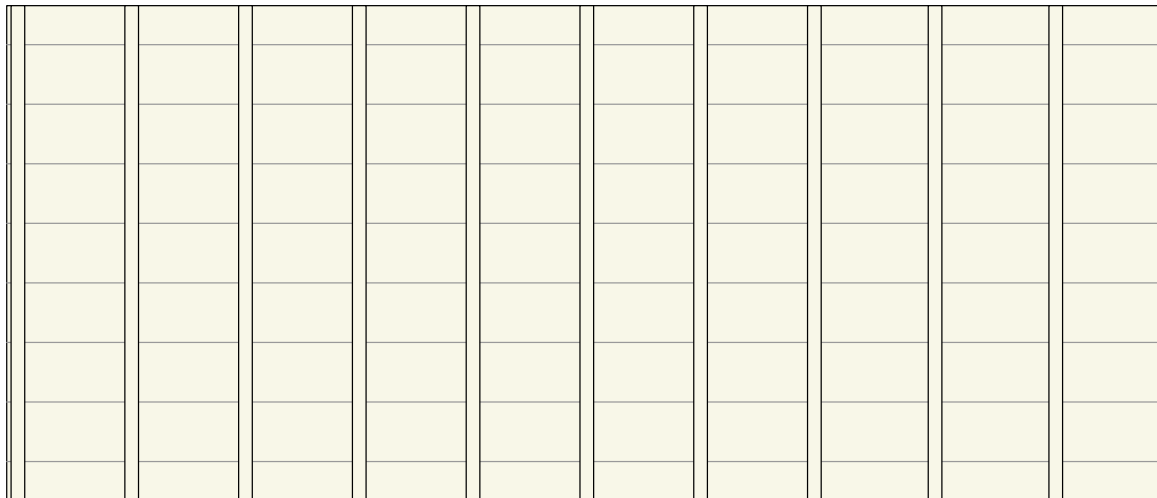

13R

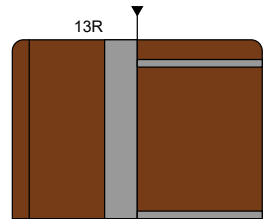

13R

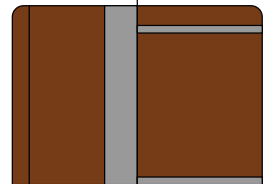

13R

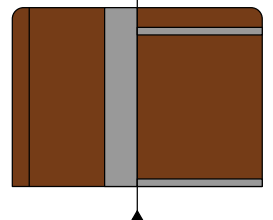

**S-TYPE LONDON BUS 1:32**  
**D: FULL LOWER SALOON - D2 -**

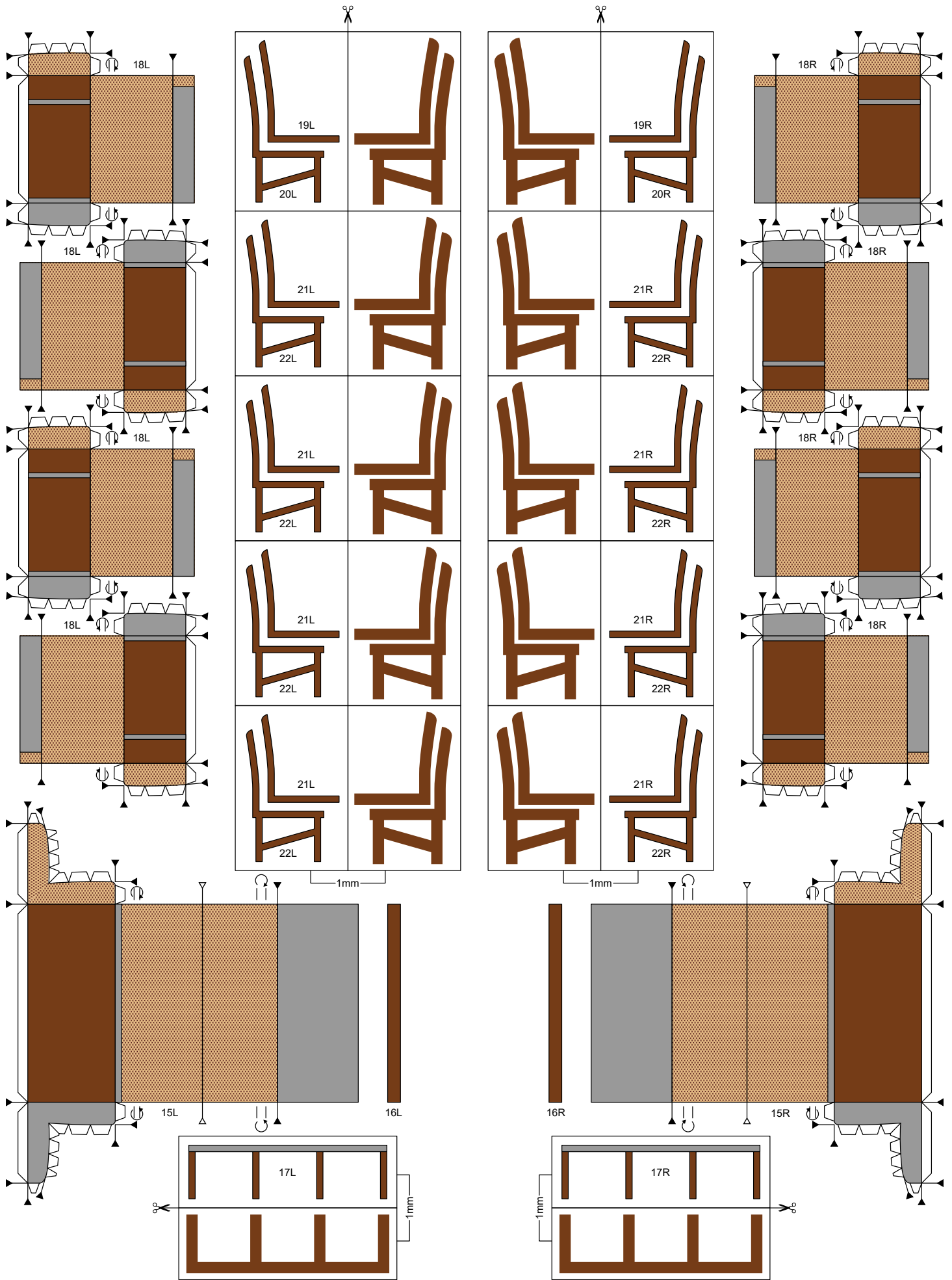

**S-TYPE LONDON BUS 1:32**  
**D: FULL LOWER SALOON - D3 -**



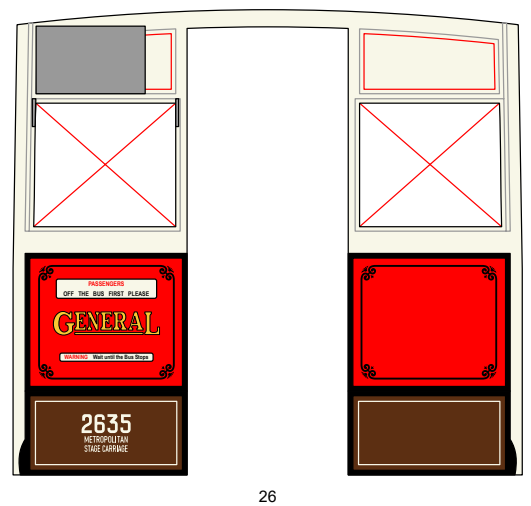
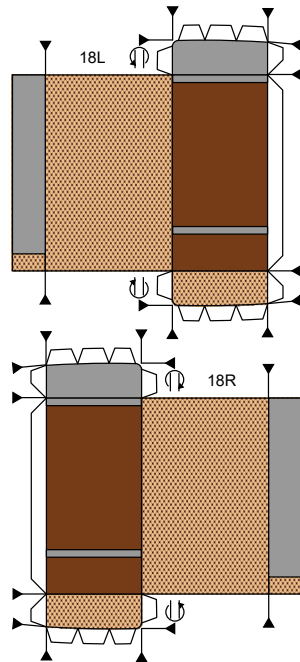
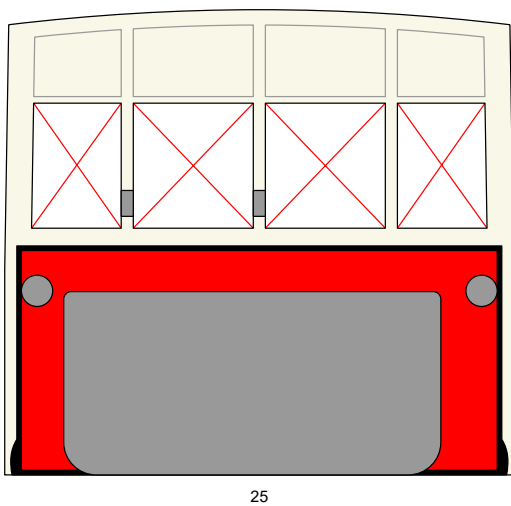
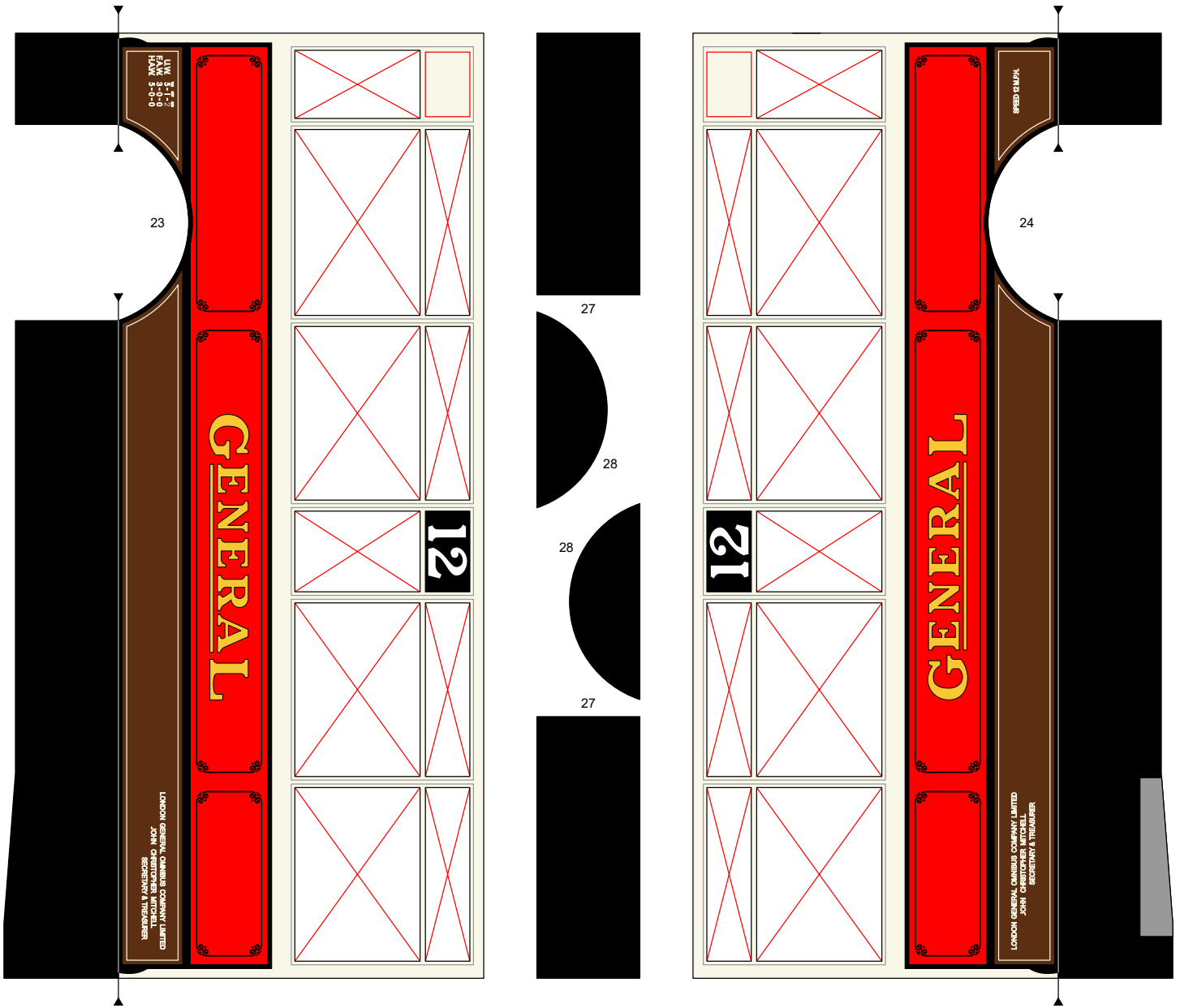

**S-TYPE LONDON BUS 1:32**  
**D: FULL LOWER SALOON - D4 -**

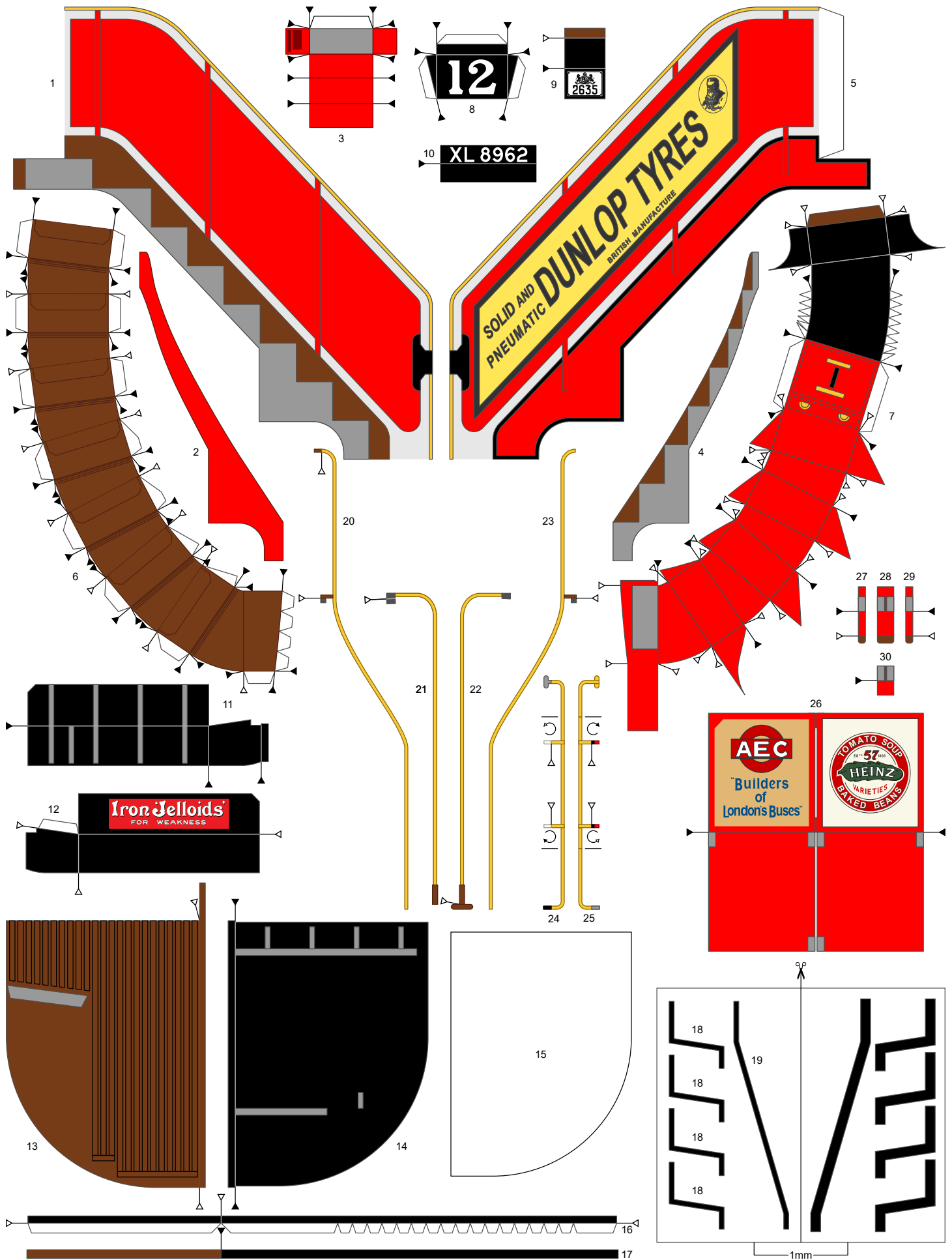

**S-TYPE LONDON BUS 1:32**  
**E: PLATFORM & STAIRS - E1 -**

Alan Grayer 2021  
 stype@grayer.me.uk

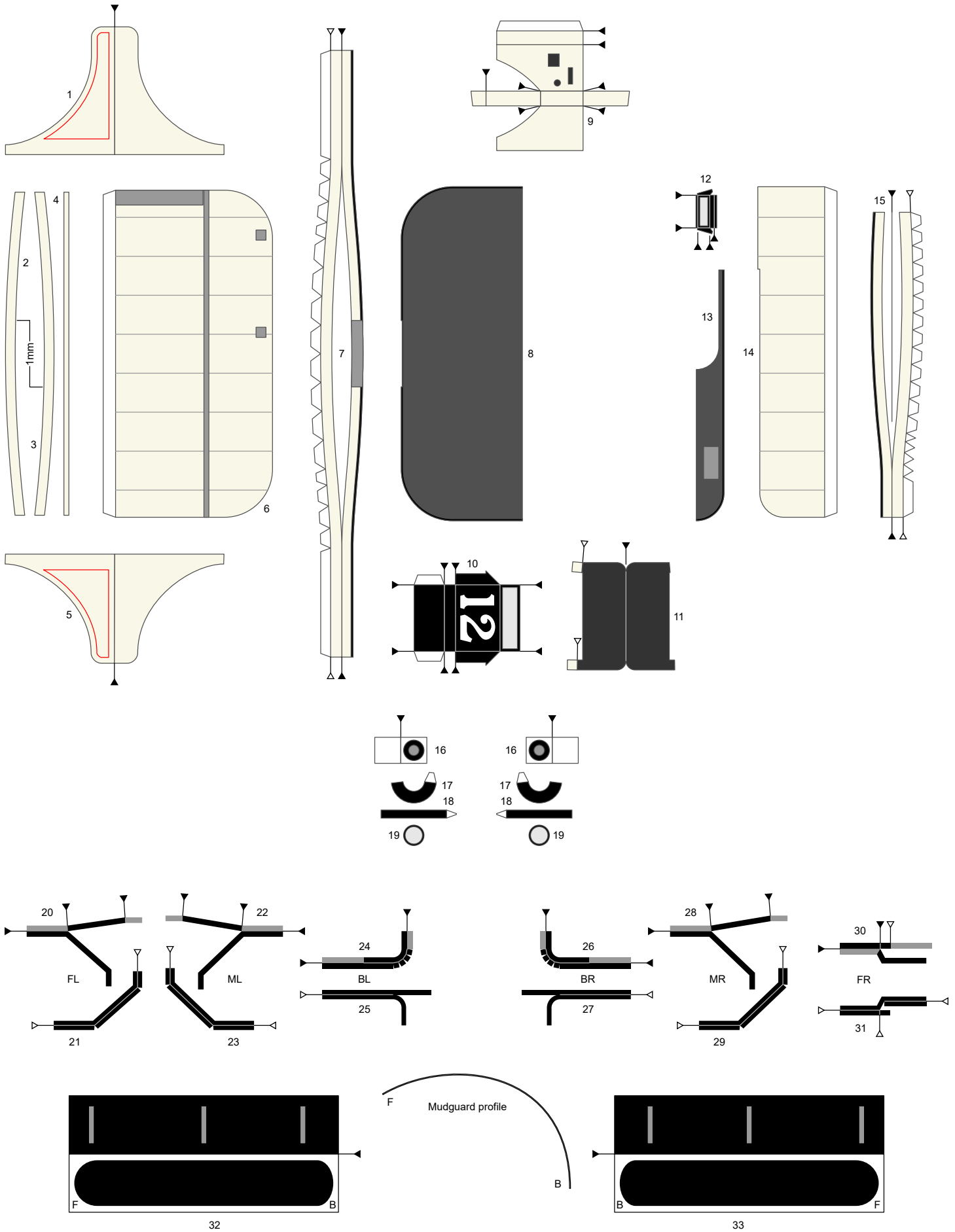

**S-TYPE LONDON BUS 1:32**  
**F: CANOPIES & GUARDS - F1 -**

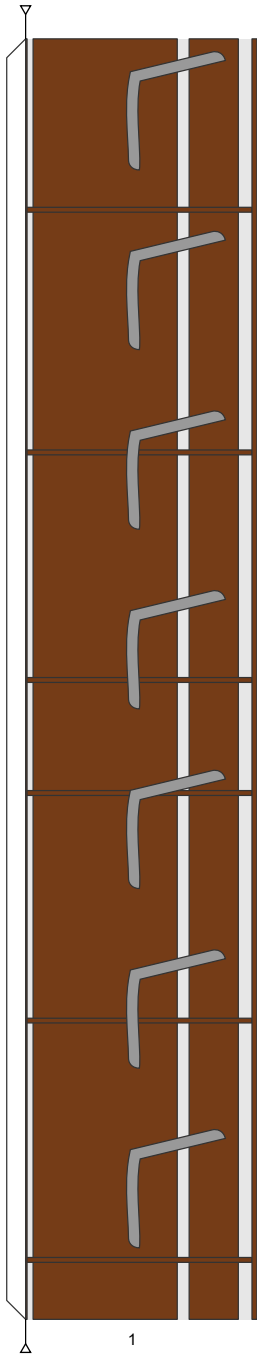

1

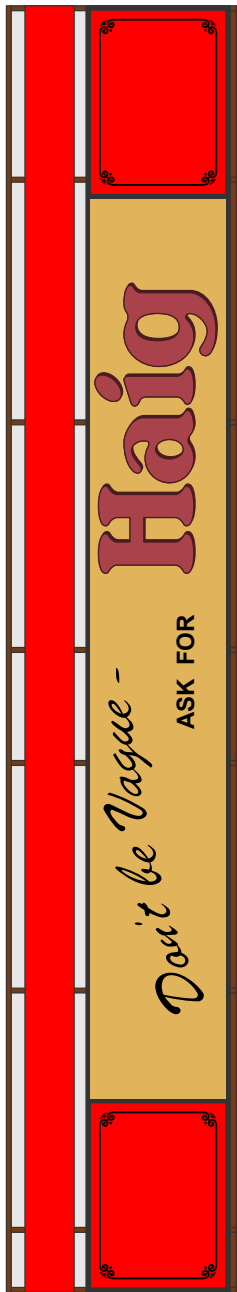

2

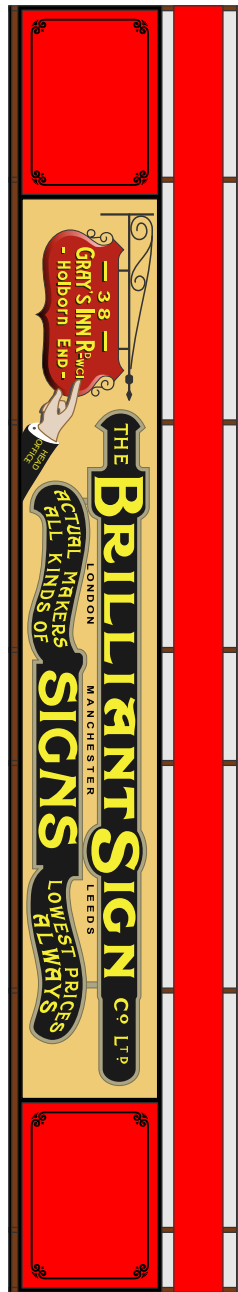

3

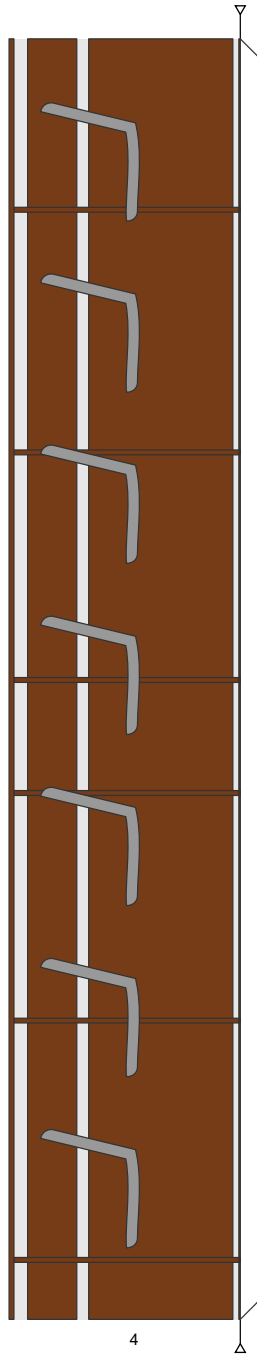

4

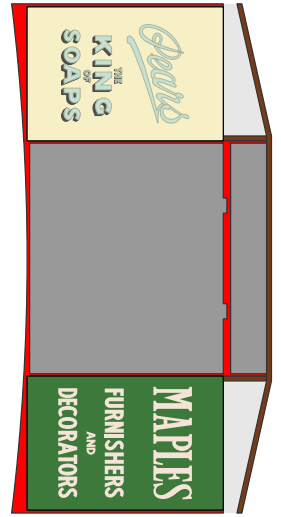

5



6

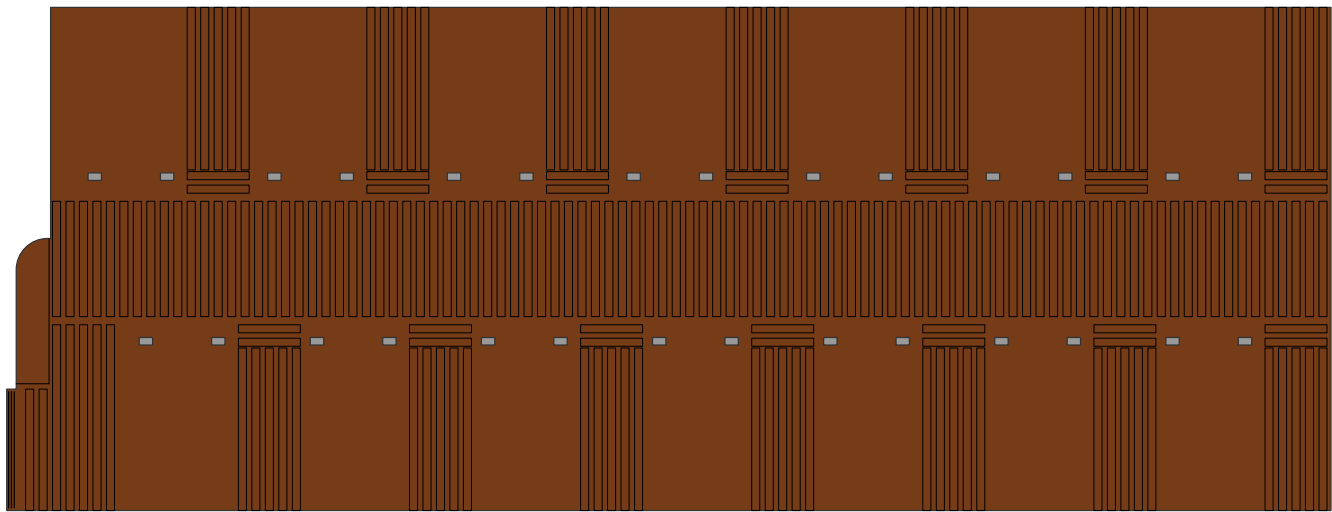

7

S-TYPE LONDON BUS 1:32  
G: UPPER DECK

- G1 -

Alan Grayer 2021  
styp@grayer.me.uk

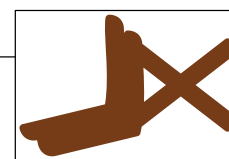
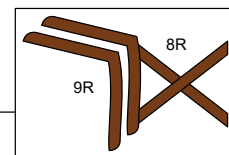
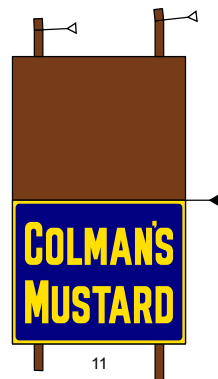
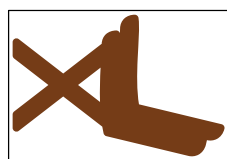
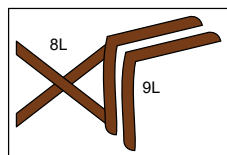
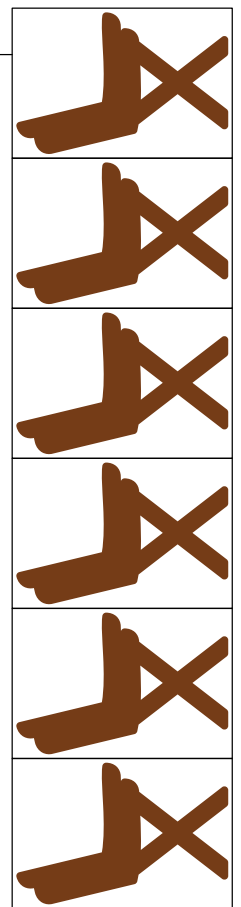
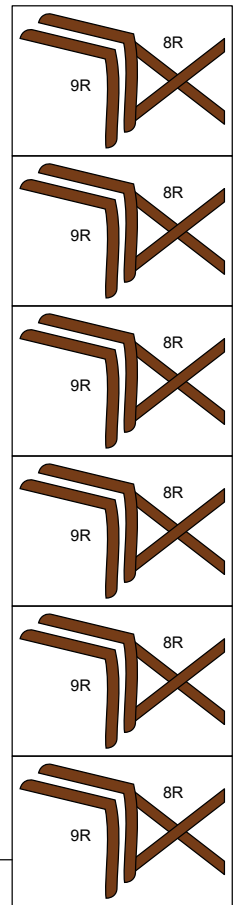
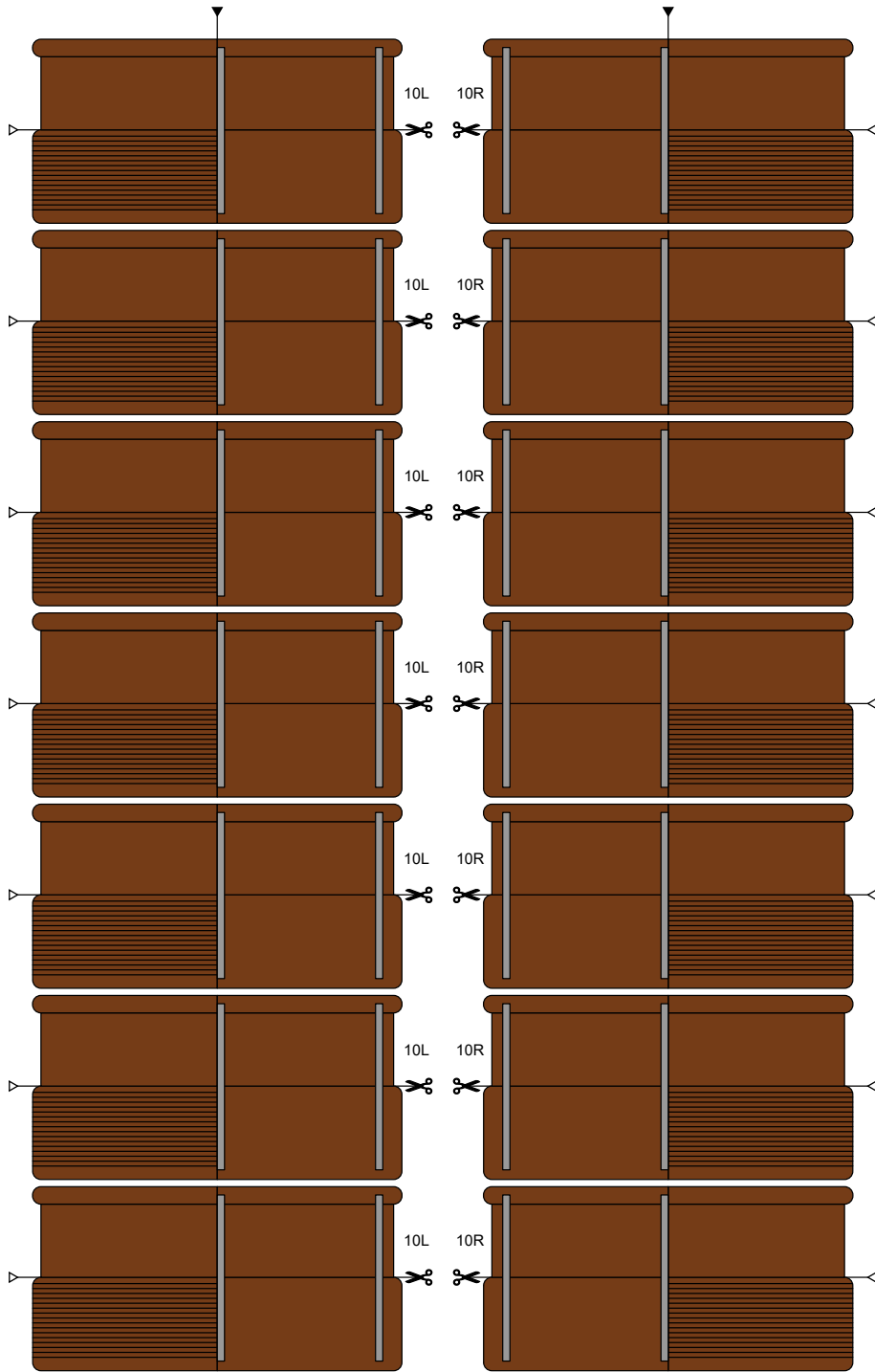
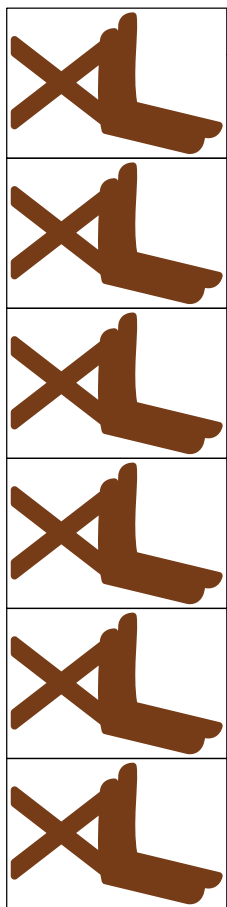
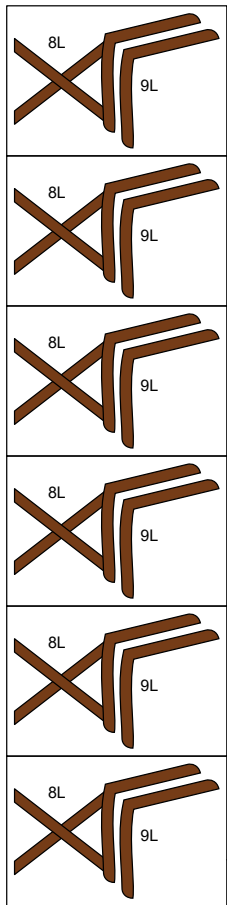

**S-TYPE LONDON BUS 1:32**  
**G: UPPER DECK**

**- G2 -**



12



14

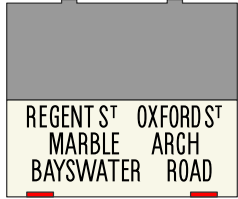

13

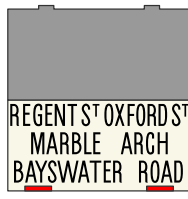

15

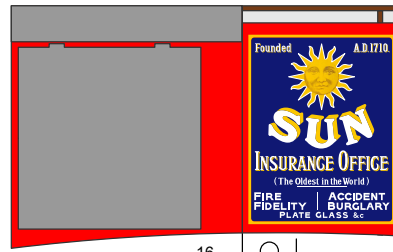

16

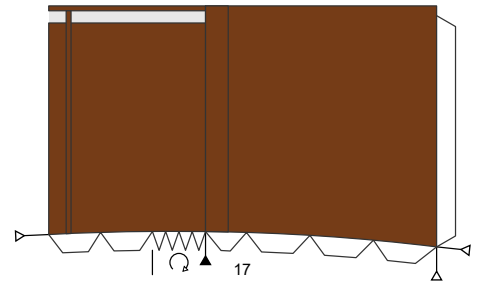

17

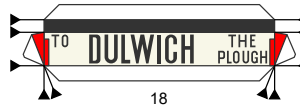

18

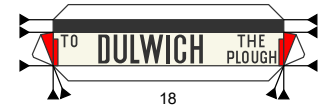

18

# G: UPPER DECK

- G3 -

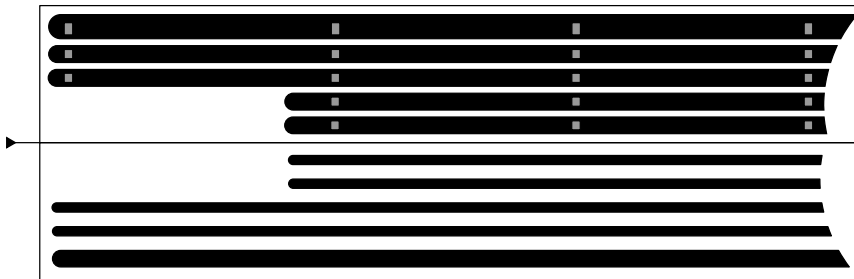

1L  
2L  
3L  
4L  
5L

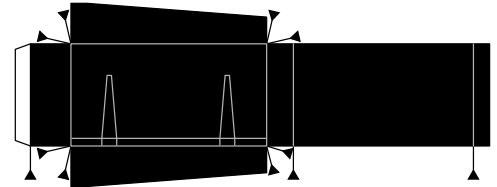

14



1R  
2R  
3R  
4R  
5R

Back Top (1L/R)  
Bottom (5L/R) Front  
Lifeguard plan

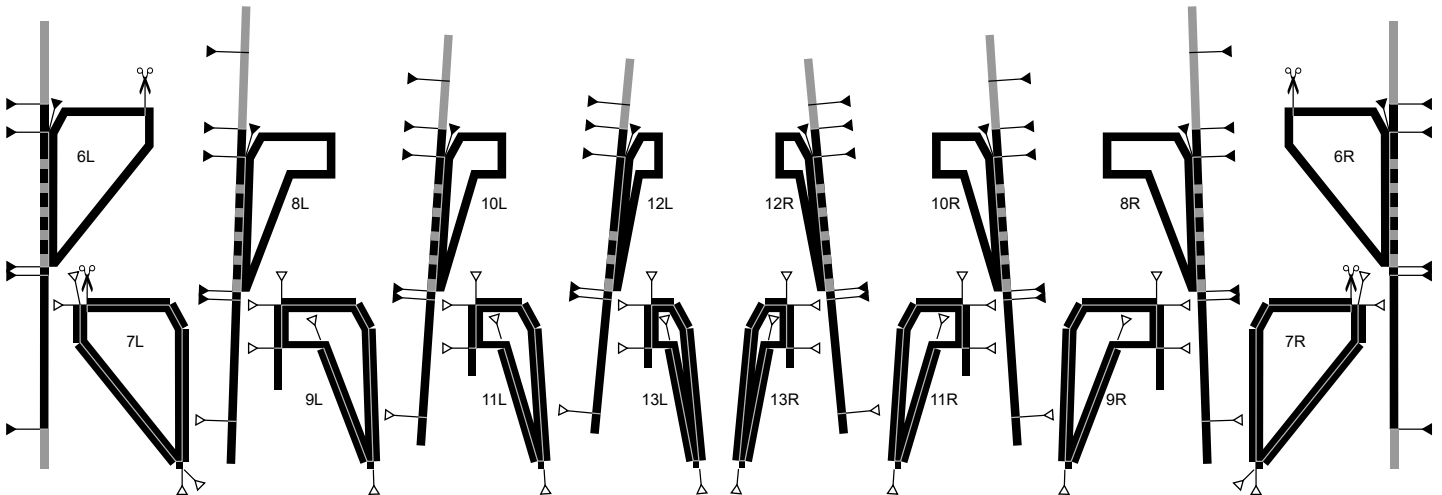

# S-TYPE LONDON BUS 1:32

## H: LIFE GUARDS

- H1 -

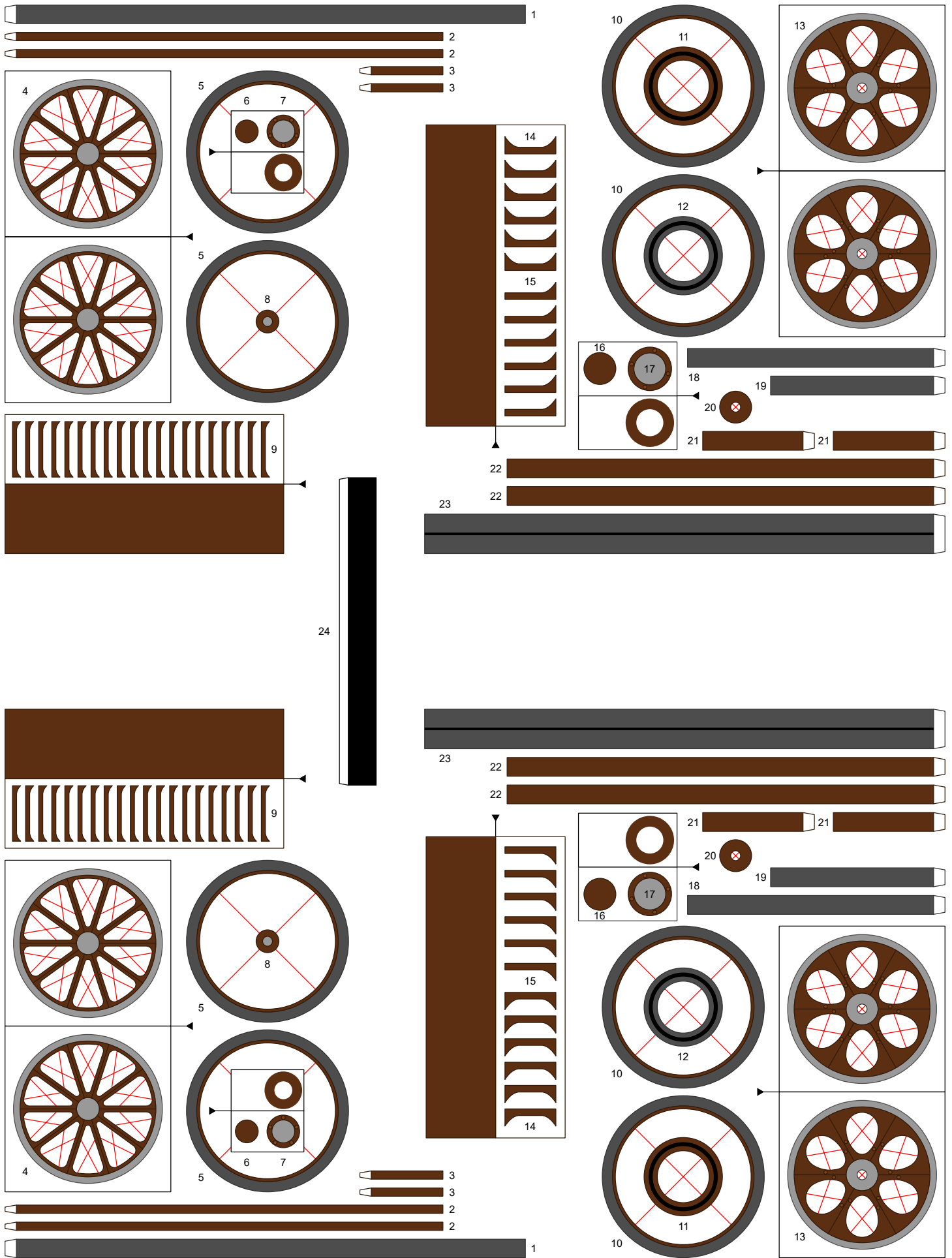

**S-TYPE LONDON BUS 1:32**  
**I: WHEELS**